

# KSC-200

*Industrial Serial RS-232 to Fiber Converter*



KSC-200

# Conversion Interfaces

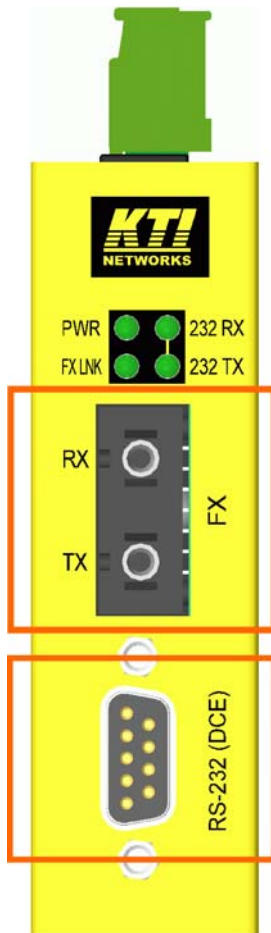

## Fiber Interface

- Duplex ST, Duplex SC, BiDi SC
- 100 Mbps

## RS232 Interface

- DB9 female
- Up to 115 Kbps
- 15 meters for distance

# Application: RS-232 Extension over Fiber

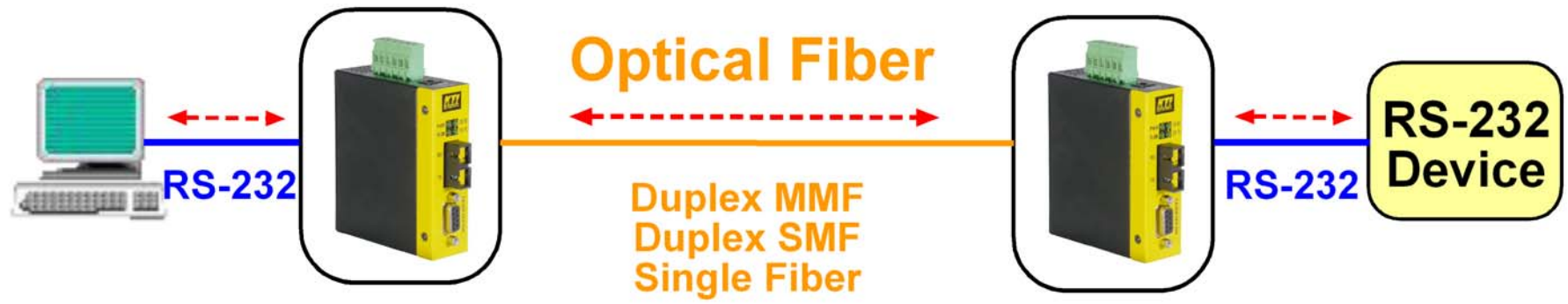

# Advantage 1: Full RS-232 Conversion

Fully compatible to all RS-232 applications with KTI's KSC-200 solution

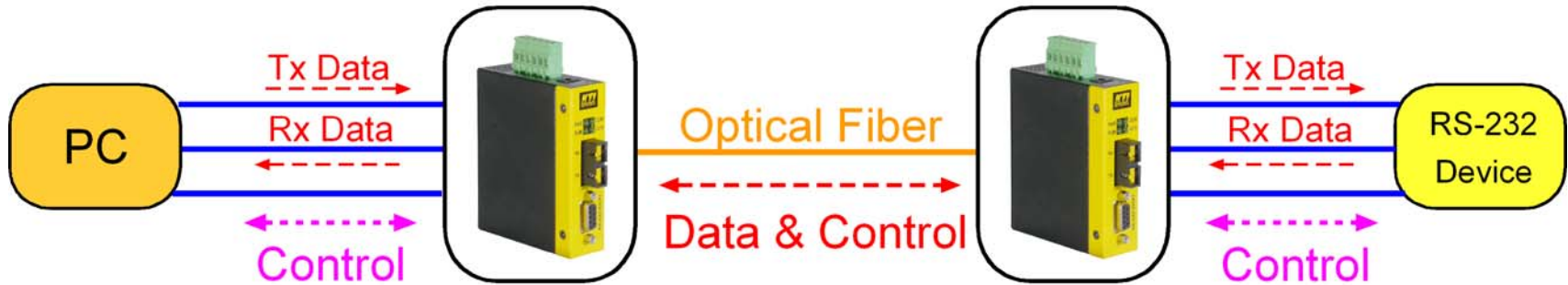

# Advantage 2: Protection & Isolation

## Surge Protection

Transient over-voltage outside +/- 28V

## Line ESD Protection

+/- 15 KV

## Optical Isolation

Isolation between RS-232 and main circuit  
3000VDC max.

# Advantage 3: Variety of Fiber Support

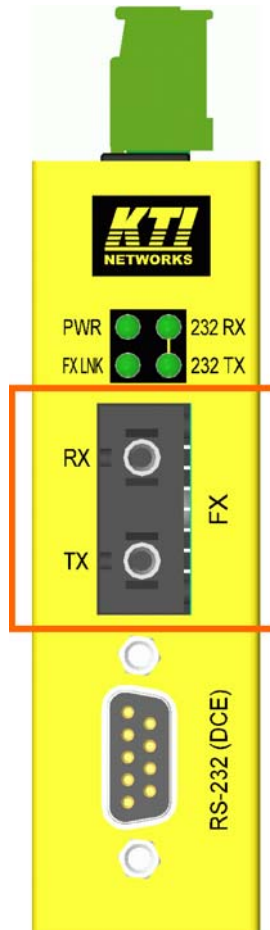

## Optical Fiber

- Duplex MMF up to 2 km
- Duplex SMF up to 20 km
- Single Fiber up to 20 km

# Benefit 1: Power Interfaces

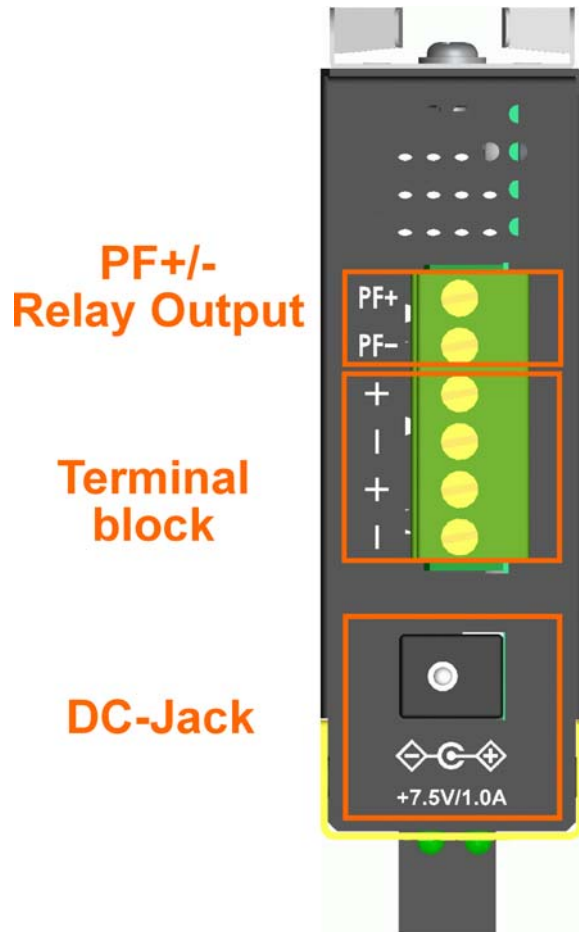

## Terminal block

Support industrial power system

## Power Failure Relay Output

Support external monitoring system

## DC-Jack

Support AC-DC adapter type power

# Benefit 2: Industrial Mounting Support

Din-Rail Mounting



Panel Mounting

