

KGS-810F

*Web Smart 8-Port Gigabit Ethernet Switch
with 1 mini-GBIC Port*



KGS-810F

Specifications

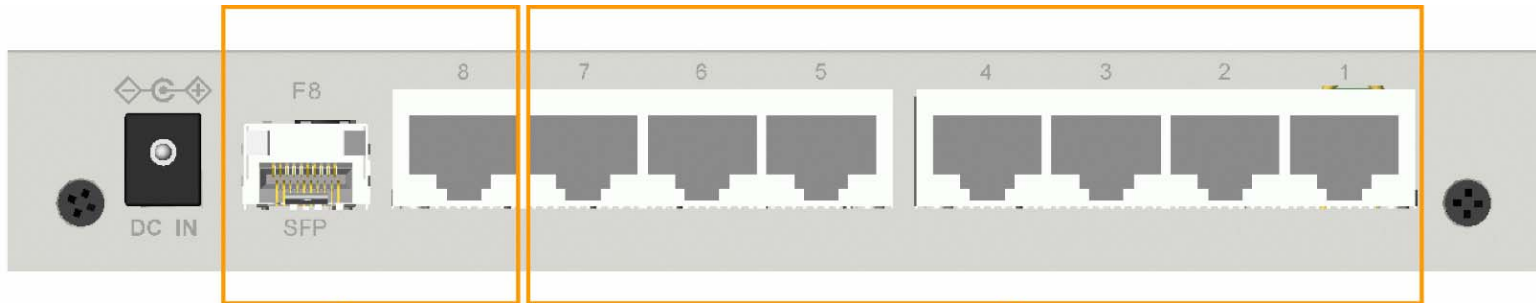

1 combo port (RJ-45+1000M SFP)

7 copper ports (10/100/1000M)

- * **Web managed**
- * **802.1Q VLAN**
- * **802.1X**
- * **RSTP**
- * **QoS**

Copper Ports

- 10/100/1000 Mbps RJ-45 support
- Auto-negotiation , Auto-MDI/MDI-X

Fiber Ports(combo with RJ-45)

- 1000 Mbps SFP support

Advantage 1 : SFP Flexibility

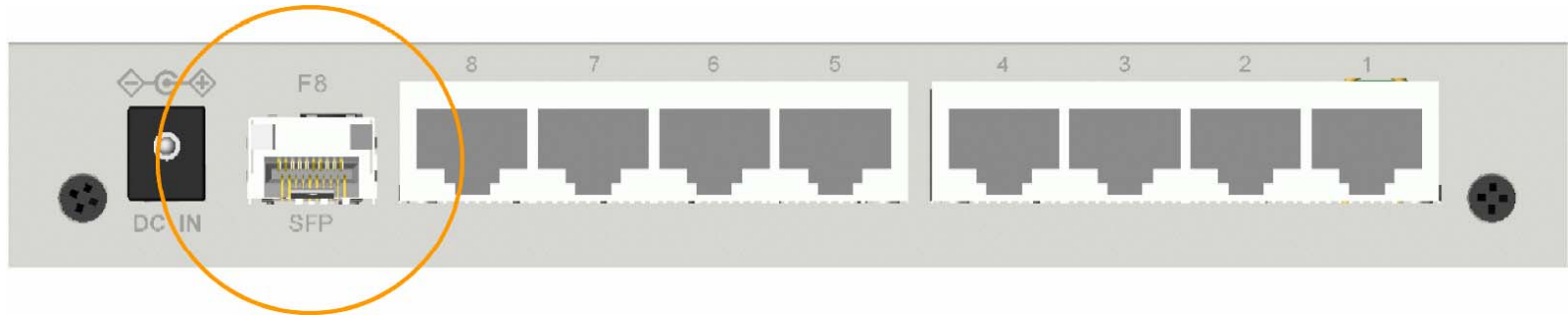

Fiber Option

- Easy migration
- Easy upgrade
- Easy maintenance

Advantage 2: Powerful Management

Configuration

System
Ports
VLAN
Aggregation
LACP
RSTP
802.1X
Mirroring
QoS
Storm Control

Monitoring

Statistics Overview
Detailed Statistics
LACP Status
RSTP Status
Ping

Maintenance

Reboot System
Restore Default
Update Firmware
Logout

All in one Compact Box



- Web managed, SNMP event trap
- VLAN
- 802.1X
- RSTP, LACP aggregation
- QoS, Storm control, Mirroring

Management 1: VLAN

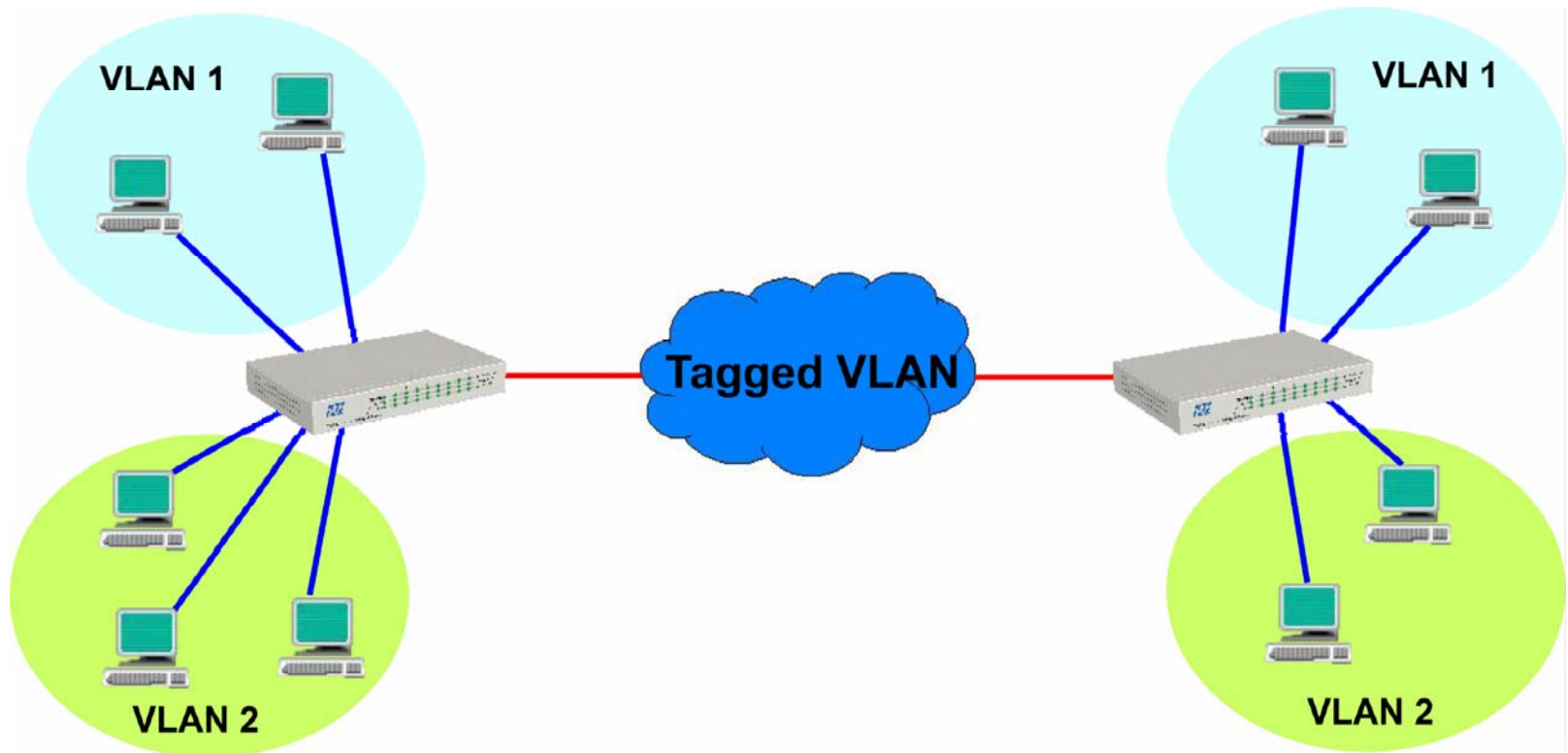

Set workgroups belonging to different VLANs

Management 2: 802.1X Authentication

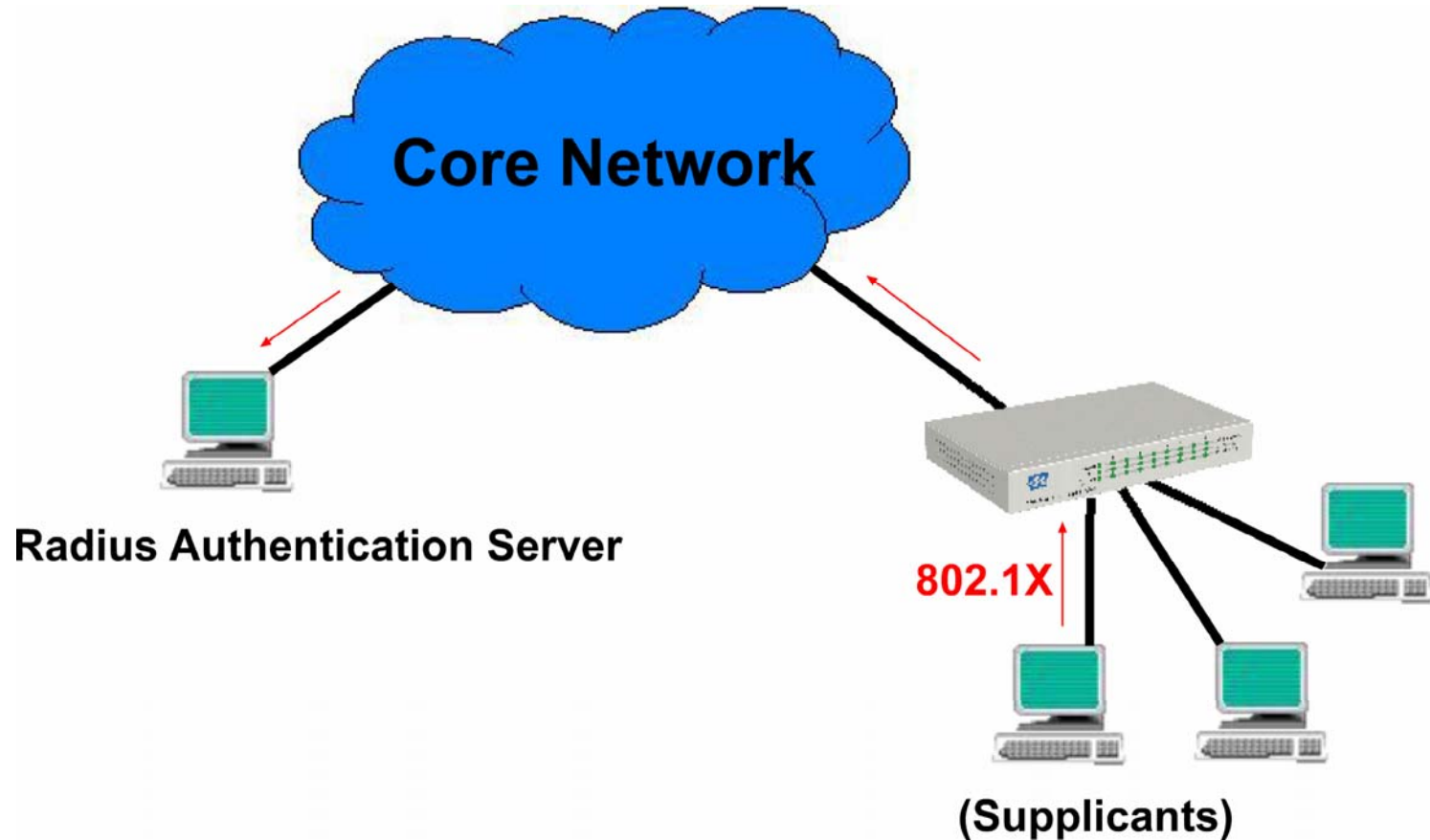

Benefit 1 : SFP DDM Support

Port	8
Identifier	SFP transceiver
Connector	LC
SONET Compliance	N/A
GbE Compliance	1000BASE-LX
Vendor Name	APAC Opto
Vendor OUI	000F99
Temperature	37 (C)
Voltage	3336 (mV)
TX Power	149 (μ W)

Basic DDM Information &

Real-time monitoring

Operating temperature

Operating voltage

Optical Transmitting Power

Benefit 2: Mounting Flexibility

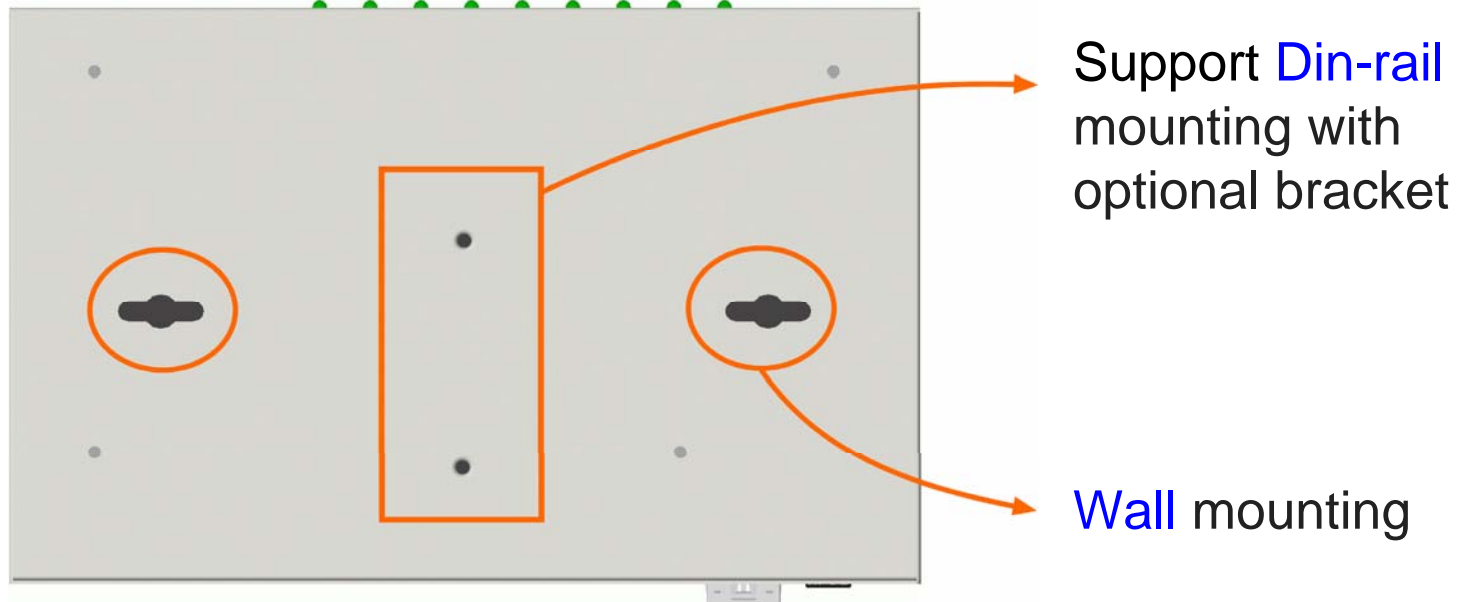

Application 1: Workgroup Switch

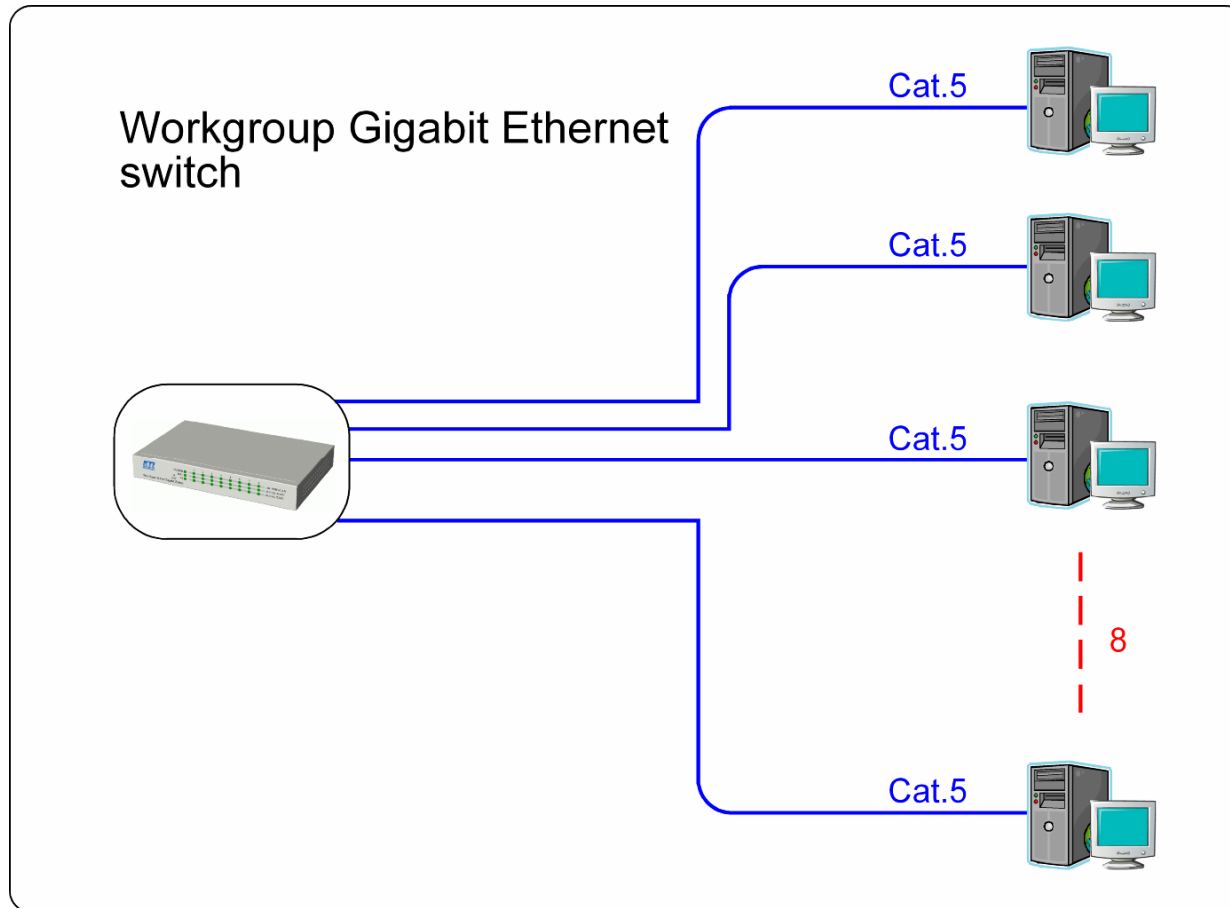

Application 2: Uplinking to fiber backbone

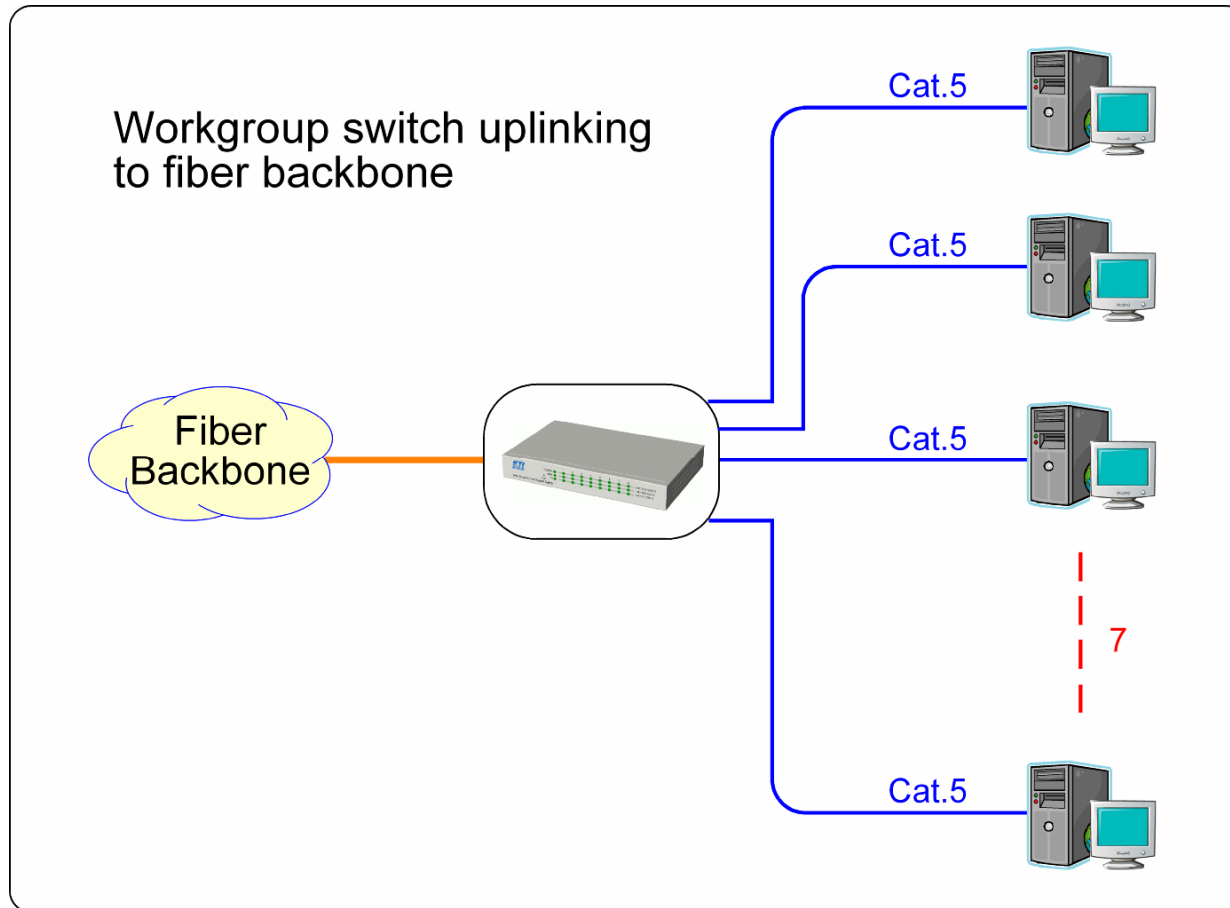

Application 3: Edge Switch for VLAN

