

# **KSD-800M**

**Industrial Managed 8-Port Fast Ethernet Switches  
with Fiber Connectivity**

## **Operation Manual**

for software v1.1 and later



DOC.140616

(C) 2012 KTI Networks Inc. All rights reserved. No part of this documentation may be reproduced in any form or by any means or used to make any derivative work (such as translation or transformation) without permission from KTI Networks Inc.

KTI Networks Inc. reserves the right to revise this documentation and to make changes in content from time to time without obligation on the part of KTI Networks Inc. to provide notification of such revision or change.

For more information, contact:

**United States**     KTI Networks Inc.  
P.O. BOX 631008  
Houston, Texas 77263-1008

Phone: 713-2663891  
Fax: 713-2663893  
E-mail: [kti@ktinet.com](mailto:kti@ktinet.com)  
URL: <http://www.ktinet.com/>

**International**     Fax: 886-2-26983873  
E-mail: [kti@ktinet.com.tw](mailto:kti@ktinet.com.tw)  
URL: <http://www.ktinet.com.tw/>

The information contained in this document is subject to change without prior notice. Copyright (C). All Rights Reserved.

#### **TRADEMARKS**

Ethernet is a registered trademark of Xerox Corp.

#### **WARNING:**

This equipment has been tested and found to comply with the limits for a Class A digital device, pursuant to Part 15 of the FCC Rules. These limits are designed to provide reasonable protection against harmful interference when the equipment is operated in a commercial environment. This equipment generates, uses, and can radiate radio frequency energy and if not installed and used in accordance with the instruction manual may cause harmful interference in which case the user will be required to correct the interference at his own expense.

#### **NOTICE:**

- (1) The changes or modifications not expressly approved by the party responsible for compliance could void the user's authority to operate the equipment.
- (2) Shielded interface cables and AC power cord, if any, must be used in order to comply with the emission limits.

#### **CISPR A COMPLIANCE:**

This device complies with EMC directive of the European Community and meets or exceeds the following technical standard.

EN 55022 - Limits and Methods of Measurement of Radio Interference Characteristics of Information Technology Equipment. This device complies with CISPR Class A.

**WARNING:** This is a Class A product. In a domestic environment this product may cause radio interference in which case the user may be required to take adequate measures.

#### **CE NOTICE**

Marking by the symbol  indicates compliance of this equipment to the EMC directive of the European Community. Such marking is indicative that this equipment meets or exceeds the following technical standards:

EN 55022: Limits and Methods of Measurement of Radio Interference characteristics of Information Technology Equipment.

EN 50082/1: Generic Immunity Standard -Part 1: Domestic Commercial and Light Industry.

EN 60555-2: Disturbances in supply systems caused by household appliances and similar electrical equipment - Part 2: Harmonics.

# Table of Contents

<b>1. Introduction</b> .....	<b>6</b>
1.1 Features .....	7
1.2 Product Panels .....	8
1.3 Front Panel .....	9
1.4 Network Ports .....	9
1.5 LED Indicators .....	10
1.6 Top Panel .....	11
1.7 Specifications .....	11
1.8 Model Definitions .....	15
<b>2. Installation</b> .....	<b>17</b>
2.1 Unpacking .....	17
2.2 Safety Cautions .....	17
2.3 DIN-Rail Mounting .....	18
2.4 Panel Mounting .....	19
2.5 Applying Power .....	21
2.6 Power Failure Relay Output .....	22
2.7 Reset Button .....	23
2.8 Making UTP Connections .....	23
2.9 Making Fiber Connections .....	24
2.10 LED Indication .....	25
2.11 Configuring IP Address for the Switch .....	26
2.12 Configuring User Name and Password .....	26
2.13 Configuring SNMP Settings .....	26
2.14 Configuring Port 7 and Port 8 .....	26
<b>3. Advanced Functions</b> .....	<b>27</b>
3.1 QoS Function .....	27
3.1.1 Priority Level .....	27
3.1.2 Egress Service Policy .....	27
3.1.3 Packet Priority Classification .....	27
3.1.3.1 Port-based Priority Setting (per port setting) .....	28
3.1.3.2 802.1p Classification (per port setting) .....	28
3.1.3.3 DSCP Classification (per port setting) .....	28
3.1.3.4 IP Network Address Classification .....	29
3.1.4 Other QoS Settings .....	29
3.2 VLAN Function .....	30
3.2.1 VLAN Operation .....	30
3.2.2 Ingress Rules .....	31
3.2.2.1 802.1Q Tag Aware VLAN Mode (global setting) .....	31
3.2.2.2 Ingress Member Filtering (global setting) .....	31
3.2.2.3 Unmatched VID Filtering (per port setting) .....	31
3.2.3 VLAN Group Mapping .....	32
3.2.4 Packet Forwarding under VLAN .....	32
3.2.5 Egress Tagging Rules .....	32
3.2.5.1 Egress Tag Rule (per port setting) .....	32

3.2.5.2 Null VID Replacement (per port setting) .....	33
3.2.6 Summary of VLAN Function .....	33
3.3 Redundant Ring Function .....	33
3.3.1 Configuration Definition .....	33
3.3.2 Fault Monitoring & Activating Backup Link .....	34
3.3.3 Repairing the Network & Standby Recovery .....	34
3.3.4 Important Notes for Applications .....	34
<b>4. Software Management .....</b>	<b>35</b>
4.1 Telnet Management Interface .....	35
4.2 IP Menu .....	36
4.3 SNMP Menu .....	37
4.4 Port Config .....	38
4.5 Administrator .....	39
4.5.1 Administrator -> VLAN Settings .....	39
4.5.2 Administrator -> QoS Settings .....	43
4.5.3 Administrator -> MAC Aging Settings .....	46
4.5.4 Administrator -> Ping .....	46
4.5.5 Administrator -> ARP Table .....	47
4.5.6 Administrator -> WDT Settings .....	47
4.6 Restore Default Values .....	48
4.7 Security Manager .....	48
4.8 Update Firmware .....	49
4.9 Reboot System .....	49
4.10 Exit .....	49
<b>5. Web Management .....</b>	<b>50</b>
5.1 Start Browser Software and Making Connection .....	50
5.2 Login to the Switch Unit .....	50
5.3 Configuration .....	52
5.3.1 Basic Menu .....	53
5.3.2 DHCP Controls .....	55
5.3.3 Port Controls .....	56
5.3.4 VLAN Controls .....	57
5.3.5 QoS Controls .....	62
5.3.6 Redundant Ring .....	65
5.3.6.1 Fault Repairing & Ring Checking .....	68
5.3.7 WDT Controls .....	70
5.4. Port Status .....	70
5.5 Maintenance .....	71
5.5.1 Security Manager .....	72
5.5.2 Update Firmware .....	72
5.5.3 Restore Default .....	73
5.5.4 Reboot System .....	73
<b>6. SNMP Management .....</b>	<b>74</b>
6.1 MIB Objects .....	74
6.2 SNMP Traps .....	74
<b>Appendix. Factory Default Settings .....</b>	<b>75</b>

# 1. Introduction

---

The KSD-800M series are managed 8-port full wire speed Fast Ethernet switches for industrial applications. Depending on the fiber connectivity, the series is provided in three types of configuration as follows:

<u>Model series</u>	<u>10/100TX TP Ports</u>	<u>100FX fiber ports</u>
800M	8 ports	-
800M-1xxx	8 ports	1 port
800M-2xxx	8 ports	2 ports



The switches provide the following advantages:

## **Plug and Play**

The switches provide eight 10/100TX copper ports for connections to Ethernet devices or 100Mbps Fast Ethernet devices. With the featured auto-negotiation function, the switches can detect and configure the connection speed and duplex automatically. The switches also provide auto MDI/MDI-X function, which can detect the connected cable and switch the transmission wire pair and receiving pair automatically. This auto-crossover function can simplify the type of network cables used.

## **Auto Copper/Fiber Connections**

The 100FX fiber ports can support 100Mbps fiber connection using optic fiber cable and extend a network connection up to several kilometers via fiber cables. The 100TX ports are designed to share the same switched ports with the associated 10/100TX copper ports. It means the switched port supports dual network media types, either copper cable or fiber cable and detect link and select the media type automatically.

## **Management**

The switches are embedded with microprocessor which provides management functions for advanced network functions including Port Control, Quality of Service, and Virtual LAN functions. The management can be performed via SNMP protocol, Telnet interface and Web based interface over TCP/IP network.

## **Designed for Industrial Applications**

For industrial environment, the switches are designed with the following enhanced features:

- High and wide operating temperature
- Wide operating voltage range for DC power input
- Power input interface: Screw terminal block and DC jack for adapter
- Relay output for device power failure alarm
- DIN rail mounting support for industrial enclosure
- Panel mounting support for industrial enclosure

## **1.1 Features**

### **Basic functions**

- Fast Ethernet switch with 8 10/100TX copper ports
- Auto MDI/MDI-X detection on all 10/100TX ports
- Auto-negotiation capable on all 10/100TX ports
- 100FX ports support wide range of fiber options
  - ST, SC connectors
  - Multi-mode fiber, Single mode duplex fiber
- Far End Fault function on 100FX ports
- Auto configuration for 10/100TX or 100FX for port 7 and port 8
- Back pressure flow control for half duplex operation
- IEEE 802.3x flow control for full duplex operation
- Broadcast storm protection function
- Provides comprehensive LED indication
- Support DIN-rail and panel mounting

### **Management functions**

- Port configuration control and status monitoring
- Provides Quality of Service (QoS) control for packet traffic
- Supports tagged Virtual LAN (VLAN) network
- Supports redundant ring function for industrial application
- Supports SNMP management interface
- Provides SNMP based event traps
- Supports Telnet management interface
- Supports Web based browsing interface
- In-band embedded firmware upgrade function

# 1.2 Product Panels

The following figure illustrates three major panels of model 800-2 series as example:

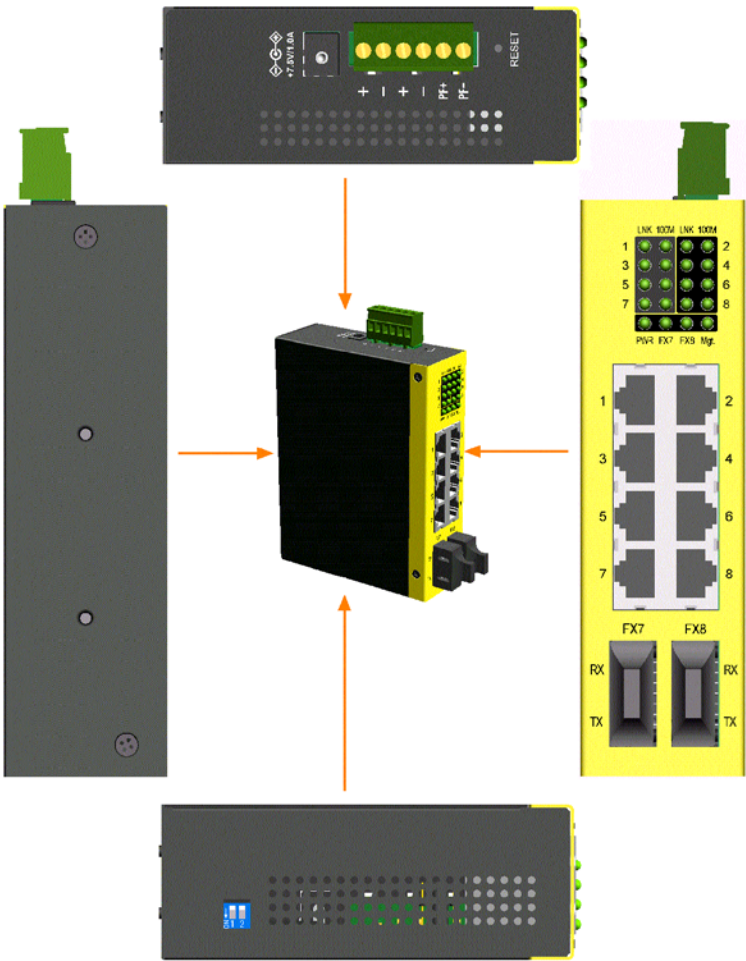

### 1.3 Front Panel

The figure below shows the individual front panel of three model series. The main difference is the number of the equipped fiber ports.

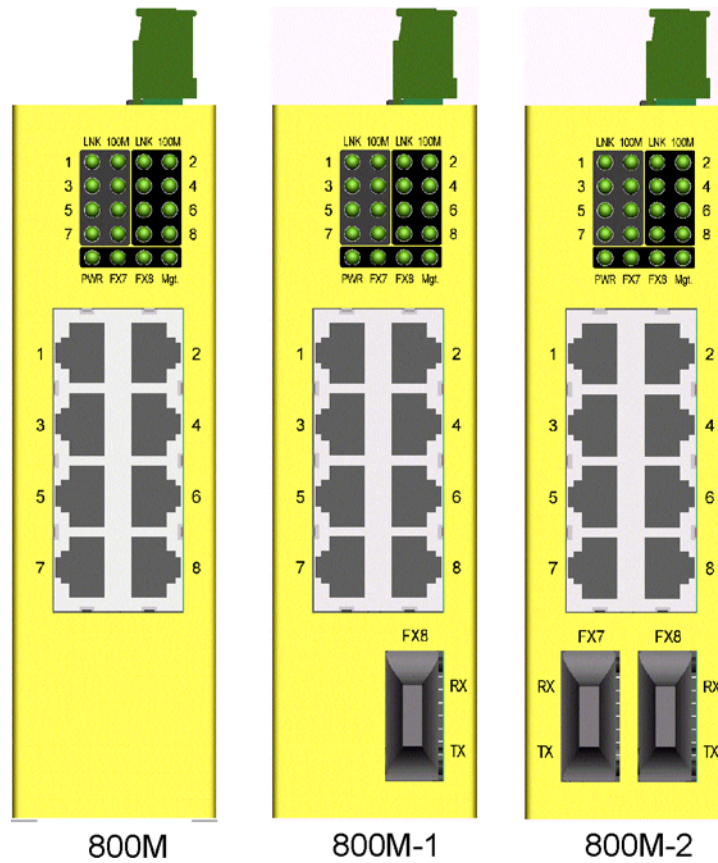

### 1.4 Network Ports

Model 800M provides eight 10/100TX copper ports only. No fiber connectivity is equipped.

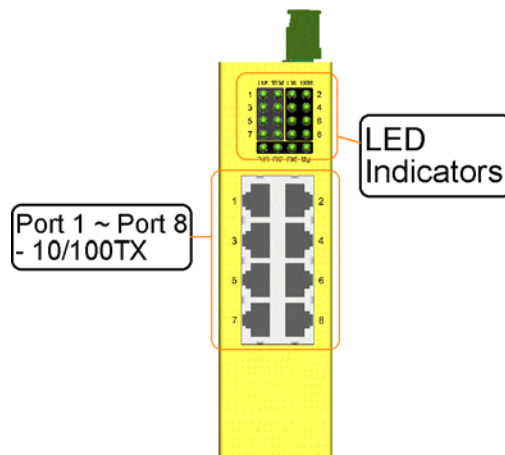

**Model 800M-1 series** provide eight 10/100TX copper ports and one 100FX fiber connector. Port 8 supports dual network cable types.

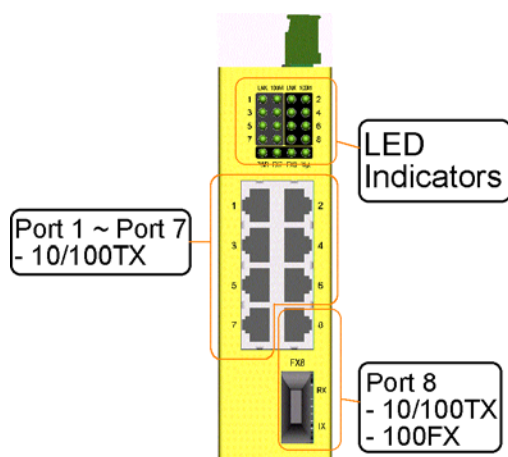

**Model 800M-2 series** provide eight 10/100TX copper ports and two 100FX fiber connectors. Port 7 and Port 8 support dual network cable types.

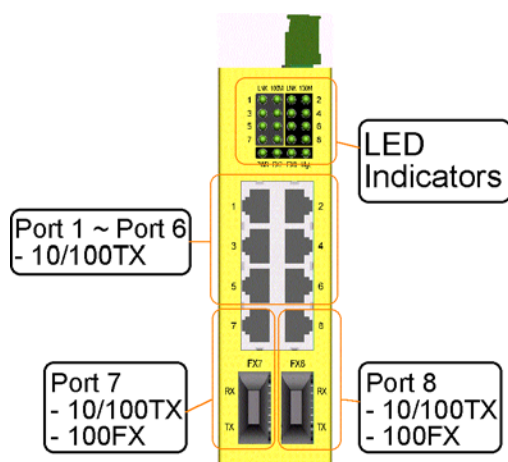

## 1.5 LED Indicators

<b>LED</b>	<b>Function</b>
PWR	Power status
LNK	Network port link status (per port)
100M	Network port speed status (per port)
FX7	Fiber port link status (if FX7 is provided on Port 7)
FX8	Fiber port link status (if FX8 is provided on Port 8)
Mgt.	Embedded microprocessor operation status

## 1.6 Top Panel

All three model series provide same top panel as figure shown below:

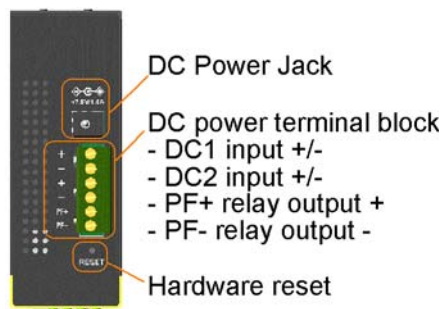

The main functions are:

---

DC Power Jack	This connector is used when a AC-DC power adapter is used as a power source to the switch.
Terminal Block	This connector provides the following interfaces: DC1 Positive(+) and Negative(-) - VDC power input from power system DC2 Positive(+) and Negative(-) - VDC power cascaded to next device PF Positive(+) and Negative(-) - Power failure relay output
Reset	Hardware reset push button

---

## 1.7 Specifications

### Network Ports

<u>Switched Port Number</u>	<u>Model 800M</u>	<u>800M-1 series</u>	<u>800M-2 series</u>
Port 1	10/100TX	10/100TX	10/100TX
Port 2	10/100TX	10/100TX	10/100TX
Port 3	10/100TX	10/100TX	10/100TX
Port 4	10/100TX	10/100TX	10/100TX
Port 5	10/100TX	10/100TX	10/100TX
Port 6	10/100TX	10/100TX	10/100TX
Port 7	10/100TX	10/100TX	10/100TX
			100FX
Port 8	10/100TX	10/100TX	10/100TX
		100FX	100FX

Note: 10/100TX - TP RJ-45, 100FX - Fiber

### **10/100TX Twisted Pair Ports**

Compliance	IEEE 802.3 10BASE-T, IEEE 802.3u 100BASE-TX
Connectors	Shielded RJ-45 jacks
Pin assignments	Auto MDI/MDI-X detection
Configuration	Auto-negotiation
Transmission rate	10Mbps, 100Mbps
Duplex support	Full/Half duplex
Flow control	IEEE 802.3x pause frame base for full duplex operation Back pressure for half duplex operation
Network cable	Cat.5 UTP

### **100FX Fiber Ports**

Compliance	IEEE 802.3u 100BASE-FX
Configuration	Forced 100Mbps, Full duplex
Transmission rate	100Mbps
Far end fault function	Capable to receive FEFI (far end fault indication) signal Capable to send FEFI signal when Rx link failure detected
Flow control	IEEE 802.3x pause frame base for full duplex operation Back pressure for half duplex operation
Network cables	MMF 50/125 60/125, SMF 9/125
Eye safety	IEC 825 compliant
Optical Specifications	Refer to Section 1.8.

### **Switch Functions**

MAC Addresses Table	1K entries
Forwarding & filtering	Non-blocking, full wire speed 10Mbps - 14,880 pps at 64-byte packets 100Mbps - 148,800pps at 64-byte packets
Switching technology	Store and forward
Maximum packet length	1536 bytes
Broadcast storm	64 consecutive broadcast packets in 800ms Protection by dropping broadcast storm packets
VLAN function	Port-based VLAN & IEEE 802.1Q Tag-based VLAN
QoS function	Port-based, 802.1p-based, IP DSCP-based, IP address-based
Port control	Port configuration control via software management

### **LED Indicators**

System	Power status, Embedded microprocessor operation status
Per 10/100TX port	TP port link/activity status, speed status
Per 100FX port	FX port link status

## **Software Management Functions**

Interfaces	Web, telnet, SNMP MIB-II & private MIB, Traps
Management objects	Port configuration control and status Username and password settings IP, SNMP related settings VLAN function settings QoS function setting

## **Port Configuration Control Function**

Configuration	P1 ~ P6
Port control function	Port TX/RX - enable, disable Port mode - Auto (auto-negotiation), Forced Port speed - 100Mbps, 10Mbps Port duplex - full, half
Port Status	Port mode, link, speed, duplex

## **VLAN Function**

VLAN groups	9 groups
Global Settings	VLAN Mode - Port-based, 802.1Q Tag Aware VLAN Ingress member port filtering mode
VLAN Group Settings	12-bit VLAN ID Member ports
Per Port Settings	Default VLAN group index Unmatched VID packet ingress filtering mode Egress Tagging Rules Null VID replacement mode (Egress)

## **QoS Function**

Priority level	2, High priority and Low priority
Priority classifications	Port-based priority mode (per port setting) 802.1p classification (per port setting) Default IP DSCP classification (per port setting) 2 user defined DSCP match classification (global) 2 user defined IP network address match classification (global)
802.1p priority tag	Threshold tag value setting for high priority (0 ~ 7)
Egress service policy	Weighted round robin ratio : 16:1, always high first, 8:1, 4:1

### **Redundant Ring Support**

Configuration                      Setting for Ring master unit or slave member unit  
   Settings for ring ports and backup port

### **DC Power Input**

Interfaces                            Euro type terminal block contacts  
   (DC1 DC2 : 2 sets for power wire cascading)  
   DC Jack ( -D 6.3mm / + D 2.0mm)

Operating Input Voltages    +7V ~ +30V(+5%)

Power consumption	Model 800M	4.7W/7.5VDC input, 5.0W/30VDC input
	Model 800M-1	6.0W/7.5VDC input, 6.3W/30VDC input
	Model 800M-2	8.0W/7.5VDC input, 8.3W/30VDC input

### **Mechanical**

Dimension (base)                140 x 106 x 40 mm

Housing                             Enclosed metal with no fan

Mounting                          Support    DIN-rail mounting, Panel mounting

Weight                              Model 800M: 465g, Model 800M-1: 475g, Model 800M-2: 485g

### **Environmental**

Operating Temperature        Typical -20°C ~ 70°C

Storage Temperature         -20°C ~ 85°C

Relative Humidity              5% ~ 95%

### **Electrical Approvals**

FCC                                  Part 15 rule Class A

CE                                  EMC, CISPR22 Class A

## 1.8 Model Definitions

<b>KSD-800M-xxx</b>	<b>Model Ext.FX Connectors</b>	<b>Wavelength (nm)</b>	<b>Reference Fiber Distance</b>	<b>Operating Temperature</b>
-1T	FX8 : ST MMF	1310	2 km	-10 ~ 70°C
-1C	FX8 : SC MMF	1310	2 km	-10 ~ 70°C
-1C1	FX8 : SC MMF	1310	2 km	-20 ~ 70°C
-1SA2	FX8 : SC SMF	1310	20 km	-20 ~ 70°C
-1SL2	FX8 : SC SMF	1310	20 km	-20 ~ 70°C
-1SL3	FX8 : SC SMF	1310	30 km	-20 ~ 70°C
-1SL4	FX8 : SC SMF	1310	40-50 km	-20 ~ 70°C
-2T	FX7 : ST MMF FX8 : ST MMF	1310 1310	2 km 2 km	-10 ~ 70°C -10 ~ 70°C
-2C	FX7 : SC MMF FX8 : SC MMF	1310 1310	2 km 2 km	-10 ~ 70°C -10 ~ 70°C
-2C1	FX7 : SC MMF FX8 : SC MMF	1310 1310	2 km 2 km	-20 ~ 70°C -20 ~ 70°C
-C1SL2	FX7 : SC MMF FX8 : SC SMF	1310 1310	2 km 20 km	-20 ~ 70°C -20 ~ 70°C
-2SA2	FX7 : SC SMF FX8 : SC SMF	1310 1310	20 km 20 km	-20 ~ 70°C -20 ~ 70°C
-2SL2	FX7 : SC SMF FX8 : SC SMF	1310 1310	20 km 20 km	-20 ~ 70°C -20 ~ 70°C
-2SL3	FX7 : SC SMF FX8 : SC SMF	1310 1310	30 km 30 km	-20 ~ 70°C -20 ~ 70°C
-2SL4	FX7 : SC SMF FX8 : SC SMF	1310 1310	40-50 km 40-50 km	-20 ~ 70°C -20 ~ 70°C

## Optical Specifications

<b>KSD-800M-xxx</b>	<b>Model Ext.FX Connectors</b>	<b>WaveL. (nm)</b>	<b>TX Power (dBm)</b>	<b>Rx Sens. (dBm)</b>	<b>Rx max. (dBm)</b>
-1T	FX8 : ST MMF	1310	-20 ~ -14	-32 max.	-8 min.
-1C	FX8 : SC MMF	1310	-20 ~ -14	-31 max.	0 min.
-1C1	FX8 : SC MMF	1310	-20 ~ -14	-31 max.	0 min.
-1SA2	FX8 : SC SMF	1310	-15 ~ -8	-31 max.	-7 min.
-1SL2	FX8 : SC SMF	1310	-15 ~ -8	-30 max.	-7 min.
-1SL3	FX8 : SC SMF	1310	-15 ~ -8	-34 max.	0 min.
-1SL4	FX8 : SC SMF	1310	-5 ~ 0	-35 max.	-3 min.
-2T	FX7 : ST MMF FX8 : ST MMF	1310 1310	-20 ~ -14 -20 ~ -14	-32 max. -32 max.	-8 min. -8 min.
-2C	FX7 : SC MMF FX8 : SC MMF	1310 1310	-20 ~ -14 -20 ~ -14	-31 max. -31 max.	0 min. 0 min.
-2C1	FX7 : SC MMF FX8 : SC MMF	1310 1310	-20 ~ -14 -20 ~ -14	-31 max. -31 max.	0 min. 0 min.
-C1SL2	FX7 : SC MMF FX8 : SC SMF	1310 1310	-20 ~ -14 -15 ~ -8	-31 max. -30 max.	0 min. -7 min.
-2SA2	FX7 : SC SMF FX8 : SC SMF	1310 1310	-15 ~ -8 -15 ~ -8	-31 max. -31 max.	-7 min. -7 min.
-2SL2	FX7 : SC SMF FX8 : SC SMF	1310 1310	-15 ~ -8 -15 ~ -8	-30 max. -30 max.	-7 min. -7 min.
-2SL3	FX7 : SC SMF FX8 : SC SMF	1310 1310	-15 ~ -8 -15 ~ -8	-34 max. -34 max.	0 min. 0 min.
-2SL4	FX7 : SC SMF FX8 : SC SMF	1310 1310	-5 ~ 0 -5 ~ 0	-35 max. -35 max.	-3 min. -3 min.

WaveL. : Wavelength, Rx Sens. : Rx sensitivity, Rx max. : Maximum Rx power

## 2. Installation

---

### 2.1 Unpacking

The product package contains:

- The switch unit
- One DIN-rail mounting kit
- One product CD-ROM

### 2.2 Safety Cautions

To reduce the risk of bodily injury, electrical shock, fire, and damage to the equipment, observe the following precautions.

- Do not service any product except as explained in your system documentation.
- Opening or removing covers may expose you to electrical shock.
- Only a trained service technician should service components inside these compartments.
- If any of the following conditions occur, unplug the product from the electrical outlet and replace the part or contact your trained service provider:
  - The power cable, extension cable, or plug is damaged.
  - An object has fallen into the product.
  - The product has been exposed to water.
  - The product has been dropped or damaged.
  - The product does not operate correctly when you follow the operating instructions.
- Do not push any objects into the openings of your system. Doing so can cause fire or electric shock by shorting out interior components.
- Operate the product only from the type of external power source indicated on the electrical ratings label. If you are not sure of the type of power source required, consult your service provider or local power company.

## 2.3 DIN-Rail Mounting

In the product package, a DIN-rail bracket is provided for mounting the switch in a industrial DIN-rail enclosure.

The steps to mount the switch onto a DIN rail are:

1. Install the mounting bracket onto the switch unit as shown below:

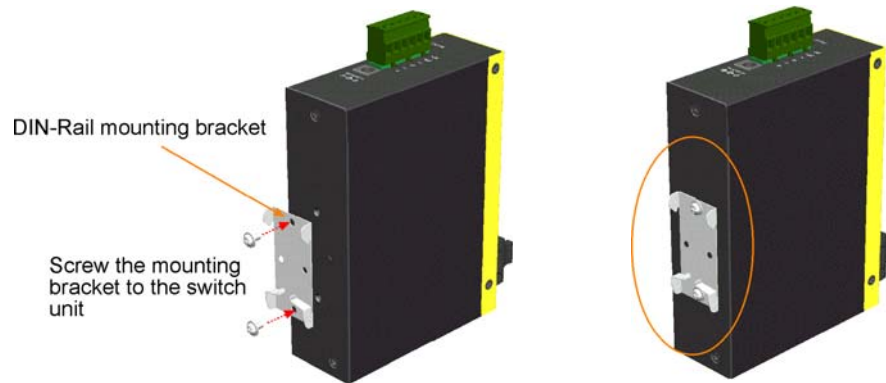

2. Attach bracket to the lower edge of the DIN rail and push the unit upward a little bit until the bracket can clamp on the upper edge of the DIN rail.
3. Clamp the unit to the DIN rail and make sure it is mounted securely.



## 2.4 Panel Mounting

The switches are provided with an optional panel mounting bracket. The bracket support mounting the switch on a plane surface securely. The mounting steps are:

1. Install the mounting bracket on the switch unit.

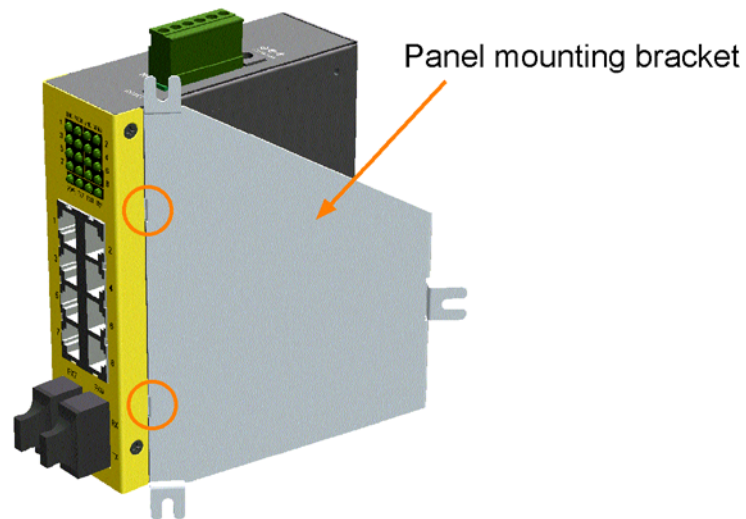

2. Screw the bracket on the switch unit.

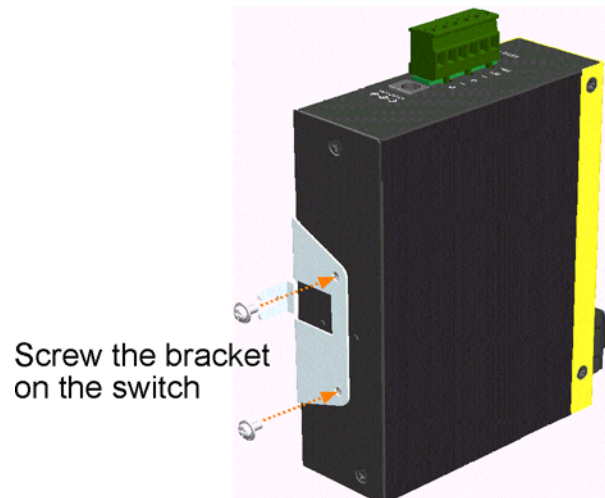

3. Screw the switch unit on a panel. Three screw locations are shown below:

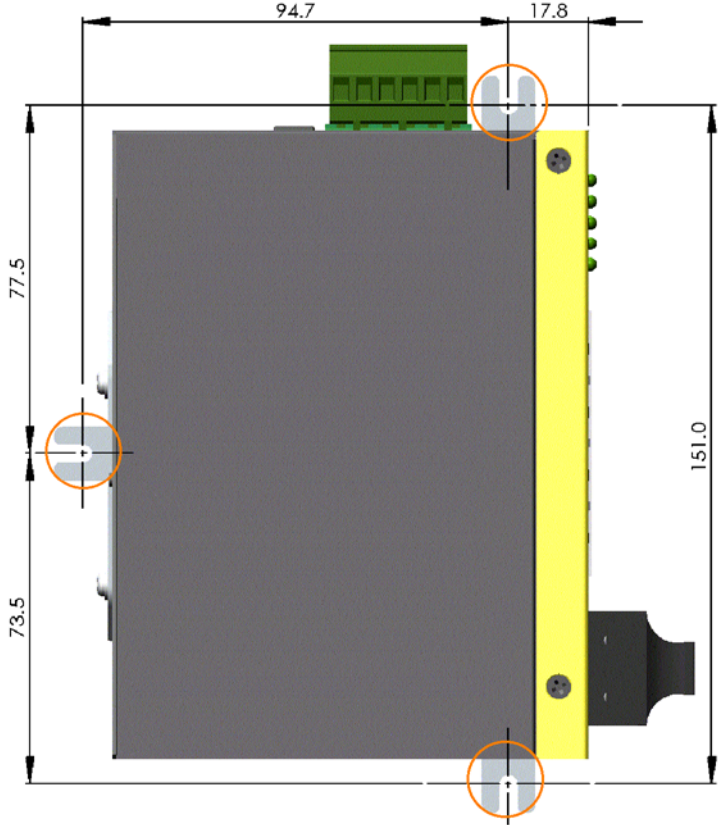

## 2.5 Applying Power

The power specifications of the switch are:

Operating Voltage    +7 ~ +30VDC  
Power Consumption    Max. 8.3W @30VDC

The switch provides two types of power interfaces, terminal block and DC power jack for receiving DC power input from external power supply.

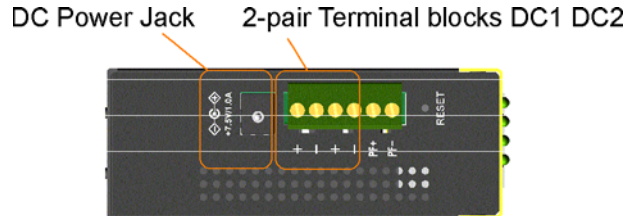

### Using Terminal Blocks

Either DC1 interface or DC2 interface can be used to receive DC power from an external power system. Or, DC2 also can be used to deliver the power received on DC1 to next switch in cascading way.

DC1 +     Vdc Positive (+) terminal  
DC1 -     Vdc Negative (-) terminal  
DC2 +     Vdc Positive (+) terminal  
DC2 -     Vdc Negative (-) terminal

Three 2P terminal plugs are provided together with the switch. Two of the three plugs are used for DC1 and DC2 interfaces respectively. The plug is shown below:



Power wires : 24 ~ 12AWG (IEC 0.5~2.5mm<sup>2</sup>)

Install the power source wires with the plug properly. Then, plug in DC1 contacts. If cascading the power to next switch device is needed, install the power wires and plug for another switch. Then, use DC2 contacts.

*Note: Only up to four device units can be cascaded to receive power from one main power input source.*

## Using DC Power Jack

When an external power system is not available, the switch provides a DC jack to receive power from typical AC-DC power adapter alternatively.

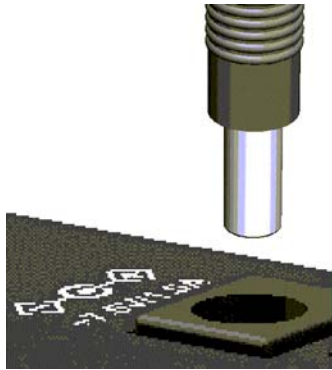

AC Power Adapters: Optional commercial rated adapters are available for purchasing.

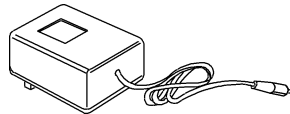

Rated AC120V/60Hz DC7.5V 1.5A  
Rated AC230V/50Hz DC7.5V 1.5A  
Rated AC100V/50-60Hz DC7.5V 1.5A  
Rated AC240V/50Hz DC7.5V 1.5A

*Note: Before you begin the installation, check the AC voltage of your area. The AC power adapter which is used to supply the DC power for the unit should have the AC voltage matching the commercial power voltage in your area.*

## 2.6 Power Failure Relay Output

The switch provides a relay output to report power failure event to a remote alarm monitoring system. The relay output is provided with two contacts in the terminal block next DC2 interface.

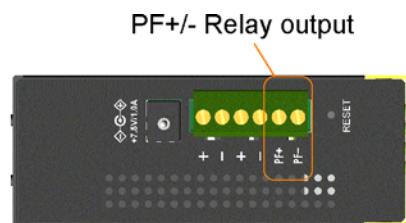

Use the provided 2P terminal plug for signal wiring and plug into the PF+/- contacts. The function is designed as :

Power is normal    PF+ contact is disconnected with PF- contact.  
Power failure      PF+ contact is shorted with PF- contact.

*Note: Be sure the voltage applied on PF+/- contacts is within the specification of 30VDC/1A max. or 120VAC/0.5A max.*

## 2.7 Reset Button

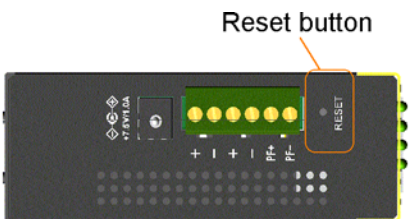

The reset button is used to perform a reset to the switch. It is not used in normal cases and can be used for diagnostic purpose. If any network hanging problem is suspected, it is useful to push the button to reset the switch without turning off the power. Check whether the network is recovered.

The button can also be used to restore the software configuration settings to factory default values. The operations are:

Operation	Function
Press the button more than 5 seconds	Restore the switch back to factory default settings
Press the button less than 5 seconds	Reboot the switch

## 2.8 Making UTP Connections

The 10/100TX ports supports the following connection types and distances:

### Network Cables

10BASE-T: 2-pair UTP Cat. 3,4,5 , EIA/TIA-568B 100-ohm

100BASE-TX: 2-pair UTP Cat. 5, EIA/TIA-568B 100-ohm

Link distance: Up to 100 meters

### Auto MDI/MDI-X Function

This function allows the port to auto-detect the twisted-pair signals and adapts itself to form a valid MDI to MDI-X connection with the remote connected device automatically. No matter a straight through cable or crossover cable is connected, the ports can sense the receiving pair automatically and configure itself to match the rule for MDI to MDI-X connection. It simplifies the cable installation.

### Auto-negotiation Function

The ports are featured with auto-negotiation function and full capability to support connection to :

- Auto-negotiation devices
- Auto-negotiation incapable 10BASE-T half duplex devices
- Auto-negotiation incapable 100BASE-TX half duplex devices

It performs a negotiation process for the speed and duplex configuration with the connected device automatically when each time a link is being established. If the connected device is also auto-negotiation capable, both devices will come out the best configuration after negotiation process. If the connected device is incapable in auto-negotiation, the switch will sense the speed and use half duplex for the connection.

### Port Configuration Management

For making proper connection to an auto-negotiation incapable device, it is suggested to use port control function via software management to set forced mode and specify speed and duplex mode which match the configuration used by the connected device.

## 2.9 Making Fiber Connections

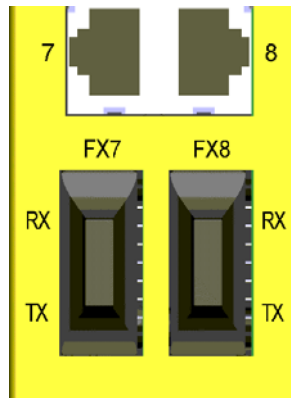

FX7 port and FX8 port operate on 100Mbps and full duplex.

The following figure illustrates a connection example between two fiber ports:

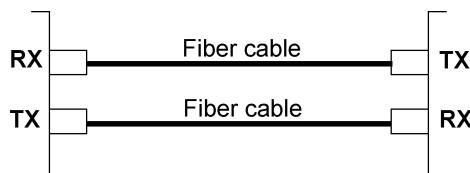

Make sure the Rx-to-Tx connection rule is followed on the both ends of the fiber cable.

### Far End Fault Function

The FX ports are facilitated with this function, which conforms to IEEE 802.3u 100BASE-FX specifications. When the FX port detects a link failure on its receiving circuitry, it will send out an FEFI (Far End Fault Indication) signal to the remote connected device to indicate a remote fault is detected. It also is capable to receive FEFI signal sent from the remote link partner. Upon receiving an FEFI signal, it indicates a link failure occurred on the transmitting path. This function allows the switch to report a fiber link fault even when a link failure occurred on transmitting fiber cable.

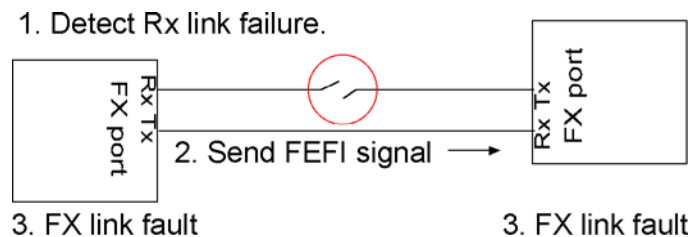

### Network Cables

Multimode (MMF) - 50/125, 62.5/125

Single mode (SMF) - 9/125

*Note: Since the FX port shares the same switched port with 10/100TX connector, make sure only one network cable type is used any time. In the case of both cable types are used at the same time, FX port has higher priority.*

## 2.10 LED Indication

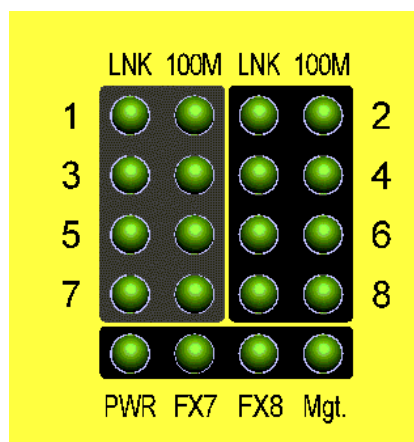

LED	Function	State	Interpretation
PWR	Power status	ON	The power is supplied to the switch.
		OFF	The power is not supplied to the switch.
LNK	Port link status	ON	An active link is established on the port. (No traffic)
		BLINK	Port link is up and there is traffic.
		OFF	Port link is down.
100M	Port speed status	ON	100Mbps
		OFF	10Mbps
FX7	FX7 link status	ON	FX7 port is link up.
		BLINK	Port link is up and there is traffic.
		OFF	Port link is down.
FX8	FX8 link status	ON	FX8 port is link up.
		BLINK	Port link is up and there is traffic.
		OFF	Port link is down.
Mgt.	Factory Reserved		Ignore the indication.

## 2.11 Configuring IP Address for the Switch

The switch is shipped with the following factory default settings for software management :

Default IP address of the switch : 192.168.0.2 / 255.255.255.0

The IP Address is an identification of the switch in a TCP/IP network. Each switch should be designated a new and unique IP address in the network. Refer to Telnet management interface.

To change the default IP address Use *Telnet IP* menu.

## 2.12 Configuring User Name and Password

The switch is shipped with the following factory default settings for software management :

- User name : *admin*
- Password : *123*

The user name and password are used for authentication in accessing to the switch via Telnet interface and Http web-based interface. For security reason, it is recommended to change the default settings for the switch before deploying it to your network. Refer to Telnet management interface.

To change user name and password Use *Telnet Security Manager* menu

## 2.13 Configuring SNMP Settings

The switch is shipped with the following factory default settings for SNMP software management :

Community strings : *public* with access right - *read only*

The community strings are used for authentication in accessing to the switch via SNMP protocol. For security reason, it is recommended to change the default settings for the switch before deploying it to your network. Refer to Telnet management interface.

To change Community strings Use *Telnet SNMP* menu

## 2.14 Configuring Port 7 and Port 8

If a 100FX is provided on Port 7 or Port 8 and 100FX fiber connection is selected, configure the port to auto-negotiation disabled, 100M, and full duplex. Refer to Telnet management interface.

To change port configuration Use *Telnet Port Config* menu

## 3. Advanced Functions

---

To help a better understanding about the software management interfaces, this chapter describes some advanced functions provided by the switch.

### 3.1 QoS Function

The switch provides a powerful Quality of Service (QoS) function to guide the packet forwarding in two priority levels. The versatile classification methods can meet most of the application needs. The following figure illustrates the QoS operation flow when a packet received on the input port until it is transmitted out from the output port:

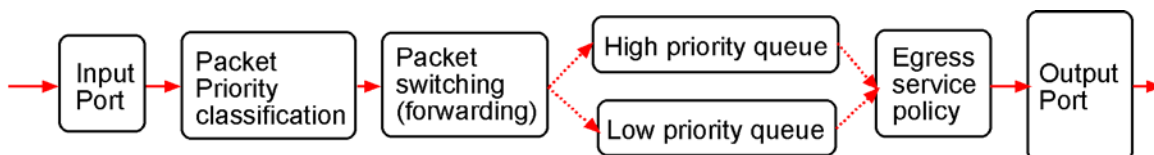

#### 3.1.1 Priority Level

Each output (egress) port in the switch is equipped with two transmission priority queues to store the packets for transmission. The high priority queue stores the high priority packets and low priority queue stores the low priority packets.

#### 3.1.2 Egress Service Policy

The packets in high priority queue and low priority queue are transmitted out from a port based on a user configured round robin ratio, called egress service policy between high priority queue and low priority queue. The switch provides four ratio options for the service policy:

- [ 4:1 ] : 4 high priority packets then 1 low priority packet
- [ 8:1 ] : 8 high priority packets then 1 low priority packet
- [ 16:1 ] : 16 high priority packets then 1 low priority packet
- [Always high priority first] : Packets in high priority queue are sent first until the queue is empty

#### 3.1.3 Packet Priority Classification

Each received packet is determined and classified into one of two priority levels, high priority and low priority upon reception. The switch provides many classification methods including:

- Port based
- 802.1p based
- IP DSCP based
- IP network address based

They all can be configured to be activated or not. Some are per port configuration and some are global configuration for the switch. More than one classification method can be enabled at the same time. If a packet is classified as high priority in any one of the enabled (applied) classifications, the packet is forwarded to the high priority queue of the output port. Otherwise, it is classified as low priority.

### 3.1.3.1 Port-based Priority Setting (per port setting)

As one port is configured to be enabled for port-based priority, all received packets on the port will be classified as high priority. The options are:

*Enable* - All packets received on the port are classified as high priority

*Disable* - Port-based classification is not applied.

### 3.1.3.2 802.1p Classification (per port setting)

For a received 802.1Q VLAN tagged packet, the switch will check the 3-bit User Priority value in TCI (Tag Control Information) field of packet tag data. If the priority value is equal or larger than a configured **802.1p High Priority Tag Setting**, the packet is classified as high priority.

*Enable* - Tagged packets received on the port are classified by comparing the packet's User Priority value and 802.1p High Priority Tag Threshold Setting.

*Disable* - 802.1p classification is not applied.

### 3.1.3.3 DSCP Classification (per port setting)

As a port is enabled for IP DSCP classification, the switch will check the DiffServ Code Point (DSCP) value of the IP packets received on the port.

*Enable* - IP packets received on the port are classified by checking the packet's DSCP value.

*Disable* - DSCP classification is not applied.

The following checks are performed to classify the packet priority:

1. **Default DSCP** : If the packet's DSCP value is one the default code point listed below, the packet is classified as high priority. EF - <101110>, AF - <001010> <010010> <011010> <100010> and Network Control - <111000> <110000>.
2. **User Defined DSCP** : If the packet's DSCP value matches the user defined DSCP(A) and DSCP(B) settings, the packet is classified as high priority. DSCP(A) and DSCP(B) settings will be described later.

User defined DSCP(A) and DSCP(B) can be enabled respectively.

#### **User Defined DSCP(A) Classification (Global)**

User can configure a specific DSCP value in **DSCP(A) setting** as high priority beside default DSCPs.

*Enable* - Enable DSCP(A) checking

*Disable* - DSCP(A) classification is not applied.

#### **User Defined DSCP(B) Classification (Global)**

User can configure a specific DSCP value in **DSCP(B) setting** as high priority beside default DSCPs.

*Enable* - Enable DSCP(B) checking

*Disable* - DSCP(B) classification is not applied.

### 3.1.3.4 IP Network Address Classification

User can configured two IP network address settings, IP(A) and IP(B). If a received IP packet's source address or destination address belongs to the user defined IP network addresses. The packet is classified as high priority.

#### **User Defined IP(A) Classification (Global)**

*Enable* - Enable IP(A) checking

*Disable* - IP(A) classification is not applied.

#### **User Defined IP(B) Classification (Global)**

*Enable* - Enable IP(B) checking

*Disable* - IP(B) classification is not applied.

### 3.1.4 Other QoS Settings

- 802.1p High Priority Tag Setting for 802.1p classification
- User Defined DSCP(A) Setting for DSCP classification
- User Defined DSCP(B) Setting for DSCP classification
- User Defined IP(A) Settings for IP network address classification
  - IP(A) IP address setting
  - IP(A) IP subnet mask setting
- User Defined IP(B) Settings for IP network address classification
  - IP(B) IP address setting
  - IP(B) IP subnet mask setting

## 3.2 VLAN Function

The switch supports port-based VLAN, 802.1Q Tag Aware VLAN and eight VLAN groups. Some VLAN related terminologies are described as follows:

### VLAN Group

VLAN group specifies a VLAN information that can be referred by the switch in performing VLAN mapping and packet forwarding for ingress port and the received packets. The information includes:

- Group Number** : index number of the VLAN group ( 1 ~ 8 )
- VID (VLAN ID)** : 12-bit value to indicate a VLAN to which the group is associated (1 ~ 4095)
- Member Ports** : the ports belong to this VLAN group for egress

### Ingress Port

Ingress port is the input port on which a packet is received.

### Default VLAN Group Index (Port VLAN index)

Each port has this index, which points to a default VLAN group. It is used for mapping a VLAN group for the ingress port under Port-based VLAN mode. It is also used for mapping to a VLAN group for an untagged received packet under 802.1Q Tag Aware VLAN mode.

### PVID (Port VID)

PVID is the default VID of an ingress port. It is obtained from the VID of the indexed default VLAN group by the ingress port. It is often used in ingress packet filtering and egress tagging operation.

### Egress Port

Egress port is the output port from which a packet is sent out after VLAN operation.

### Null VID Packet

A tagged packet is called Null VID packet if the packet's VID is equal to 0. Sometimes, it is also called priority tag packet.

### 3.2.1 VLAN Operation

The following figure illustrates the basic VLAN operation flow beginning from a packet received on an ingress port until it is transmitted from an egress port.

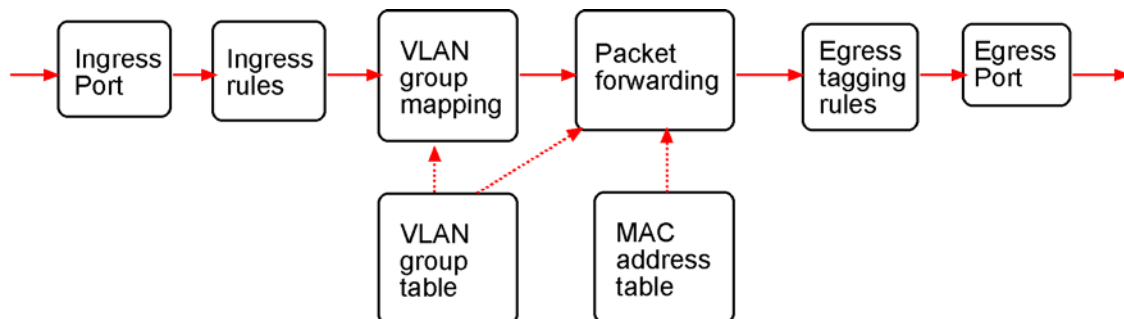

The following sections describe the VLAN processes and related settings provided by the switch. A global setting means the setting is applied to all ports of the switch. A per port setting means each port can be configured for the setting respectively.

### 3.2.2 Ingress Rules

When a packet is received on an ingress port, the ingress rules are applied for packet filtering and mapping a VLAN group. The first rule is :

#### 3.2.2.1 802.1Q Tag Aware VLAN Mode (global setting)

*Enable* - 802.1Q Tag Aware VLAN mode is used

*Disable* - Port-based VLAN mode is used

##### 802.1Q Tag Aware VLAN Mode

Under this mode, the switch will check the content of every received packets. For 802.1Q tagged packets, the tagged VID on the packet is used to look up the VLAN group table and find the group whose VID matches the packet tagged VID.

<u>Received packet type</u>	<u>VLAN group mapping</u>	<u>Final VLAN group used</u>
802.1Q Tagged packets	Tagged VID	Matched - use the matched VLAN group No matched - drop the packet
Untagged packets	Port VLAN index	Default VLAN group of the ingress port

##### Port-based VLAN Mode

Under this mode, the switch does not check the contents of the received packets. The default VLAN group indexed by the ingress port is used directly for further VLAN operation.

#### 3.2.2.2 Ingress Member Filtering (global setting)

As this rule is enabled, the received packet is dropped if the ingress port is not the member port of the mapped VLAN group.

*Enable* - Drop packet if the ingress port is not the member port of the VLAN group

*Disable* - No ingress member filtering is applied

#### 3.2.2.3 Unmatched VID Filtering (per port setting)

A tagged received packet will be dropped if the tagged VID does not match the PVID of the ingress port. PVID is the VID of ingress port 's default VLAN group.

*Enable* - Drop the tagged packet if the packet 's VID does not match the ingress port 's PVID

*Disable* - No Unmatched VID filtering is applied to the port

### 3.2.3 VLAN Group Mapping

The VLAN group mapping is the switch's decision process to find a right VLAN group for the received packet when it is not filtered by ingress rules. The group mapping depends on the VLAN mode and the packet type. The following table lists the decision rules:

<u>VLAN Mode</u>	<u>Packet Type</u>	<u>Mapping Method</u>
802.1Q Tag Aware	Tagged & non-Null	Use packet's VID to loop up VLAN group table Matched - use the group matched Unmatched - drop the packet
802.1Q Tag Aware	Null VID	Use ingress port's default VLAN group directly
802.1Q Tag Aware	Untagged	Use ingress port's default VLAN group directly
Port-based VLAN	Tagged	Use ingress port's default VLAN group directly
Port-based VLAN	Untagged	Use ingress port's default VLAN group directly

### 3.2.4 Packet Forwarding under VLAN

The forwarding is a switch's process to forward the received packet to one or more egress ports. The process uses the following information as forwarding decision:

- The mapped VLAN group's member ports : the port range for forwarding
- The packet's destination MAC address : for MAC address table loop up
- The switch's MAC address table : to find the associated input port for a learned MAC address

If the MAC address table lookup is matched and the associated port is the VLAN member port, the packet is forwarded to the port (egress port). If the lookup is not matched, the switch will broadcast the packet to all member ports.

### 3.2.5 Egress Tagging Rules

Egress Tagging rules are used to make change to the packet before it is transmitted out from an egress port. Two egress tagging settings are provided for each port and are described as follows:

#### 3.2.5.1 Egress Tag Rule (per port setting)

Four basic options are provided for egress tagging :

##### 1. Tagging with PVID for all packets

Untagged packet : the packet is inserted with the associated ingress port's PVID as tag VID

Tagged packet : the packet's tag VID is replaced with ingress port's PVID as new tag VID

##### 2. Untagging for all packets

Untagged packet : the packet is not modified

Tagged packet : the packet's tag VID is removed and becomes an untagged packet

Null VID packet : depending on Null VID Replacement setting in next section

##### 3. PVID insertion for untagged packets only

Untagged packet : the packet is inserted with the associated ingress port's PVID as tag VID

Tagged packet : the packet is not modified

##### 4. No tag insertion and tag removal

The packet is not modified at all. No tag insertion or tag removal are performed for all packets.

### 3.2.5.2 Null VID Replacement (per port setting)

The null VID of a Null VID packet will be replaced with the associated ingress port's PVID. This setting still works even Egress Tag rule : [*PVID insertion for untagged packets only*] is selected.

### 3.2.6 Summary of VLAN Function

**Number of VLAN groups** : 8 groups at the same time

**VLAN ID supported** : 1 ~ 4095 (12-bit VID)

**VLAN mode options** : 802.1Q Tag Aware VLAN, Port-based

**Ingress rules** : Ingress Member Filtering (global setting)  
Unmatched VID Filtering (per port setting)

**Egress Tagging rules** : Egress Tag Rule (per port setting)

- Tagging with PVID for all packets
- Untagging for all packets
- PVID insertion for untagged packets only
- No tag insertion and tag removal

Null VID Replacement (per port setting)

## 3.3 Redundant Ring Function

For industrial applications, multiple switches are often connected like a cascaded chain due to topology limitation. In such configuration, a backup (redundant) mechanism with fast response is also required to keep the network operating when any cable fault or even device fault occur.

### 3.3.1 Configuration Definition

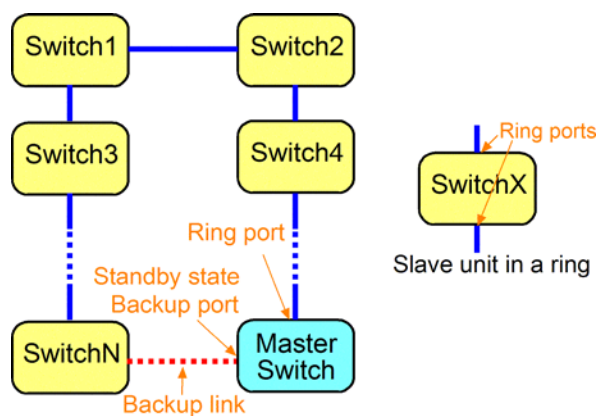

**Slave Units:** All switch units except the master switch in a ring configuration

**Master Unit:** The unit which monitors the ring configuration and controls the backup link

**Ring Ports:** The ports used for connecting ring switch units

**Backup Port:** The port specified in the master unit which is connected to a physical cable but is disabled in operation of standby state. It is enabled immediately when a fault is detected by the master unit.

In building a redundant ring network configuration, the backup link must be connected securely and has NO RISK for FAILURE. The switch provides a user friendly management interface to configure the ring network. It also provides a helpful function to examine the status of all members in a ring. However, this function is a proprietary design which is not compatible with similar function provided in other switches. Refer to section 5.4.5 for more information about how to configure a ring network.

### 3.3.2 Fault Monitoring & Activating Backup Link

The master monitors the network continuously. As any fault is reported, the master activates (enable) the backup link in standby state immediately to recover the communication channel and keep the network operating. The fault may be ring cable disconnection as shown in the left figure below:

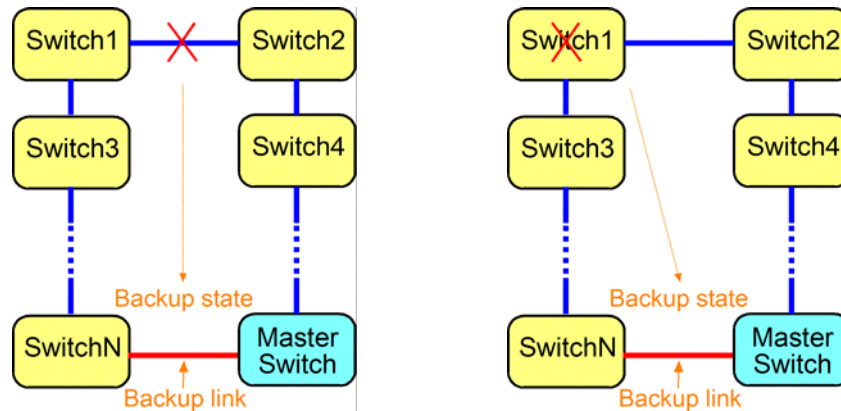

From standby state, the backup link enters into backup state. Other possible faults could be a switch failed due to function failure or power problem as shown in the above right figure.

The redundant ring function can support not only one fault case but also multiple faults cases at the same time and give much faster response time than typical Spanning Tree Protocol. Other faults happening outside this scope is beyond the monitoring capability of the switch.

### 3.3.3 Repairing the Network & Standby Recovery

When the backup link is activated to support continuous network operation, the failed section in the ring is blocked and isolated for physical examination and repairing by network administration people. After the failure is repaired, the master provides a useful interface for administrator to examine the health of the network until all elements and whole network are sure to recover back to normal condition. The ring network can enter into standby state (on guard) again. Refer to section 5.4.5 for more information about how to recover the network after repairing.

### 3.3.4 Important Notes for Applications

1. The function is not compatible with similar functions available in other brands of switches.
2. The faults to be monitored are cable connections of ring ports and the switch members in a ring network. Other faults beyond these scope are not supported.
3. The cabling of the backup link should be protected securely and has no risk for any failure.
4. When the backup link is activated, the faults should be investigated and repaired immediately.
5. The backup link will not switch to standby state by itself, but only by administrator manually. The administrator should make sure all faults are removed and network is healthy and switches the backup link to backup state.

## 4. Software Management

---

The switch provides the following in-band management interfaces for configuring the switch to meet requirements for different applications:

- Telnet over TCP/IP
- Http web-based over TCP/IP
- SNMP over TCP/IP

### 4.1 Telnet Management Interface

Use Telnet software to perform the management operation. The most convenient solution is using the built-in Telnet function in your Windows PC. Execute **Telnet** command as follows:

```
>telnet xxx.xxx.xxx.xxx
```

The specified xxx.xxx.xxx.xxx is the IP address of the switch. Factory default IP address is 192.168.0.2.

A welcome message and login prompt are displayed if the connection is established properly.

---

```
Welcome to Telnet Server
```

```
login:xxxxx  
password: xxx  
Welcome xxxxx
```

---

Factory default login name : admin

Factory default password : 123

It is suggested to change the user name and password first before performing other configuration. To change the user name and password, select [6] *Security Manager* for configuration.

#### Main Menu

---

```
INET>  
Setup Menu  
TCP/IP stack vx.xx  
[0] Print this menu  
[1] IP Menu  
[2] SNMP Menu  
[3] Port Config  
[4] Administrator  
[5] Restore Default Values  
[6] Security Manager  
[7] Update firmware  
[8] Reboot System  
[Q] Exit  
Please Select(0-9)....
```

---

*Note: If [Unchange] option is provided during configuration, it means keeping current setting.*

## 4.2 IP Menu

Select [1] *IP Menu* to configure IP protocol related settings for the switch.

---

```
IP Menu:
[0] Print this menu
[1] Set IP Address
[2] View IP status
[3] Set DHCP Client
[Q] Back Menu
Please Select(0-3)....
INET>1
```

Enter Esc to abort..

```
Please Input IP Address(xxx.xxx.xxx.xxx):192.168.0.232
replacing net[0] IP address192.168.0.232 with 192.168.0.232
Please Input Subnet Mask(xxx.xxx.xxx.xxx):255.255.255.0
replacing subnet mask[0]255.255.255.0 with 255.255.255.0
Please Input Gateway IP(xxx.xxx.xxx.xxx):192.168.0.1
replacing gateway IP addr[0] 192.168.0.1 with 192.168.0.1
Do you want to Change IP setting?(Y/N):
```

---

---

IP Settings	Description
IP Address :	IP address assigned to the switch
Subnet Mask :	IP subnet mask of the switch
Gateway IP :	IP address of the default gateway of the switch

---

To view current IP settings of the switch, select [2] *View IP status*.

---

```
IP Menu:
[0] Print this menu
[1] Set IP Address
[2] View IP status
[3] Set DHCP Client
[Q] Back Menu
Please Select(0-3)....
INET> 2
```

```
IP Addr: 192.168.0.232 Submask: 255.255.255.0 Gateway: 192.168.0.1
```

```
INET>
```

---

To use DHCP for IP settings of the switch, select [3] *Set DHCP Client*.

---

```
DHCP Controls:
DHCP Client : Disabled
Lease Time  : 0 (sec)
```

```
Enter Esc to abort..
(1)Enable (2)Disable
DHCP Client(1/2): 1
```

---

DHCP client function is used to lease IP configuration for the switch from a DHCP server dynamically. The lease time shown is the lease time left for the lease IP address assigned by the DHCP server.

### 4.3 SNMP Menu

This menu is used for configuring SNMP protocol related settings.

---

```
Snmp Menu:
[0] Print this menu
[1] View Snmp Setting
[2] Set Snmp Name
[3] Set Snmp Location
[4] Set Snmp Contact
[5] Set Snmp Community
[6] Set Snmp Trap Manager
[7] Set Port Link Trap Function
[8] Set Login Failure Trap Function
[Q] Back Menu
Please Select(0-9)....
INET>
```

---

---

<b>SNMP Settings</b>	<b>Description</b>
System Name	Name of the switch for SNMP management
System Location	Location of the switch for SNMP management
System Contact	Contact person for the switch
Community Name	Community Name allowed for SNMP access to the switch Up to 4 communities can be configured.
Community Access Right	Access Right associated to the community name, options <i>R(read-only)</i> - only read operation is allowed <i>W(read-write)</i> - both read and write operations are allowed.
Trap Manager	IP Address of the SNMP station which can receives trap Up to 3 trap stations can be configured.
Trap Community Name	Community string sent with a trap message
Port Link Trap Function	Enable or disable SNMP trap for port link change events
Login Failure Trap Function	Enable or disable SNMP trap for login failure events

---

## 4.4 Port Config

Select [3] *Port Config* to configure port configuration.

---

```
Port Config Menu:
[0] Print this menu
[1] Port Status
[2] Port Config
[Q] Back Menu
Please Select(0-3)
```

---

Select [1] *Port Status* to view current port status for all ports as example below:

---

```
INET> Port Status:
Port  Port Link  Auto    Speed Duplex Port      Auto_No  Speed  Duplex
+-----+-----+-----+-----+-----+-----+-----+-----+-----+
  1    TP   Down   --     --    --    Enable  Enable  100 M  Full
  2    TP   Down   --     --    --    Enable  Enable  100 M  Full
  3    TP   Down   --     --    --    Enable  Enable  100 M  Full
  4    TP   Down   --     --    --    Enable  Enable  100 M  Full
  5    TP   Down   --     --    --    Enable  Enable  100 M  Full
  6    TP   Up     Enable  100 M  Full   Enable  Enable  100 M  Full
  7    TP   Down   --     --    --    Enable  Enable  100 M  Full
  8    TP   Down   --     --    --    Enable  Enable  100 M  Full
+-----+-----+-----+-----+-----+-----+-----+-----+-----+
INET>
```

---

---

Status	Description
Port	The port number
Port Type	<i>TP</i> - 10/100TX port (for Port 7 and Port 8 10/100TX is selected) <i>FX</i> - 100FX is selected (for Port 7 and Port 8 only)
Link Status	Port link status <i>Down</i> - port link down (no status is displayed.) <i>Up</i> - port link up
Auto Negotia.	Auto-negotiation configuration <i>Enable</i> - auto-negotiation is enabled <i>Disable</i> - auto-negotiation is disabled (forced mode is used)
Speed Status	Port speed status <i>100M</i> - 100Mbps is used <i>10M</i> - 10Mbps is used
Duplex Status	Port duplex status <i>Full</i> - full duplex is used <i>Half</i> - half duplex is used
Port Control	Port function configuration <i>Enable</i> - Port function (Tx/Rx) is enabled <i>Disable</i> - Port function (Tx/Rx) is disabled
Auto-No Control	Port auto-negotiation function <i>Enable</i> - enable port auto-negotiation <i>Disable</i> - disable port auto-negotiation (use forced mode)

---

Speed Control	Speed configuration when auto-negotiation is disabled <i>100M</i> - 100Mbps <i>10M</i> - 10Mbps
Duplex Control	Duplex configuration when auto-negotiation is disabled <i>Full</i> - full duplex <i>Half</i> - half duplex

---

Select [2] *Port Config* to view current port status for all ports as example below:

Port Setting	Description
Ports	Select port range to be configured. More than one group can be configured at the same time. Examples: 123 - Port 1, Port 2, Port 3 1 2 3 - Port 1, Port 2, Port 3 1,2,3 - Port 1, Port 2, Port 3
Port Control	Enable / disable port function (Tx/Rx)
Auto Negotiation	Enable / disable port auto-negotiation function
Speed	Configure speed when port auto-negotiation function is disabled
Duplex	Configure duplex when port auto-negotiation function is disabled

---

## 4.5 Administrator

Select [4] *Administrator* to configure advanced settings including VLAN and QoS settings:

```
Administrator:
[0] Print this menu
[1] VLAN Settings
[2] QoS Settings
[3] MAC Aging Settings
[4] Ping
[5] ARP Table
[6] WDT Settings
[Q] Back Menu
Please Select(0-6,Q)....
```

---

### 4.5.1 Administrator -> VLAN Settings

Select [1] *VLAN Settings* to configure VLAN function related settings:

```
VLAN Settings Menu:
[0] Print this menu
[1] VLAN Group Information
[2] VLAN Select
[3] VLAN Global Settings
[4] VLAN Group Member Settings
```

[5] VLAN Group VID Settings  
 [6] VLAN Per Port Settings  
 [Q] Back Administrator  
 Please Select(0-7)

Select [1] VLAN Group Information to view all groups.

VLAN Select: Disable VLAN

Member Ports (0 : member, - : not member):

G\P	1	2	3	4	5	6	7	8
1	0	0	0	0	0	0	0	0
2	-	0	-	-	-	-	-	-
3	-	-	0	-	-	-	-	-
4	-	-	-	0	-	-	-	-
5	-	-	-	-	0	-	-	-
6	-	-	-	-	-	0	-	-
7	-	-	-	-	-	-	0	-
8	-	-	-	-	-	-	-	0

VLAN ID:

Group	1	2	3	4	5	6	7	8
VLAN ID	1	2	3	4	5	6	7	8

INET>

VLAN Information	Description
VLAN Select	VLAN function of the switch is enabled or disabled.
Member ports	Table list for member ports : X axis - port number Y axis - group number
VLAN ID	VLAN ID configuration of each group

Select [2] VLAN Select to enable or disable VLAN function of the switch.

Select [3] VLAN Global Settings to configure 802.1Q Tag Aware Mode and Ingress Member Filtering Mode:

VLAN Other Settings:  
 [0] Print this menu  
 [1] View VLAN Global Settings  
 [2] 802.1Q Tag Aware Mode  
 [3] Ingress Member Filtering Mode  
 [Q] Back VLAN  
 Please Select(0-4)

<b>VLAN Global Settings</b>	<b>Description</b>
802.1Q Tag Aware Mode	<p><i>Enable</i> - Under this mode, the switch will check the content of every received packets. For 802.1Q tagged packets, the tagged VID on the packet is used to look up the VLAN group table and find the group whose VID matches the packet tagged VID.</p> <p><i>Disable</i> - Under this mode, the switch does not check the contents of the received packets. The default VLAN group indexed by the ingress port is used directly for further VLAN operation.</p>
Ingress Member Filtering Mode	<p><i>Enable</i> - Drop packet if the ingress port is not the member port of the VLAN group</p> <p><i>Disable</i> - No ingress member filtering is applied</p>

Select [4] *VLAN Group Member Settings* to configure member ports for VLAN groups.

<b>Input</b>	<b>Description</b>
Groups	<p>Specify group list to be configured. More than one group can be configured at the same time. Examples:</p> <p>123 - Group 1, Group 2, Group 3</p> <p>1 2 3 - Group 1, Group 2, Group 3</p> <p>1,2,3 - Group 1, Group 2, Group 3</p>
Ports	<p>Enter port list for the selected groups</p> <p>Examples:</p> <p>123 - Port 1, Port 2, Port 3</p> <p>1 2 3 - Port 1, Port 2, Port 3</p> <p>1,2,3 - Port 1, Port 2, Port 3</p>

Select [5] *VLAN Group VID Settings* to configure VLAN ID for VLAN groups.

<b>VID Setting</b>	<b>Description</b>
Groups	Select group list to be configured.
VLAN ID	<p>Enter VLAN ID for the selected groups</p> <p>Valid values : 1 - 4095</p>

Select [6] *VLAN Per Port Settings* to configure VLAN ID for VLAN groups.

VLAN Per Port Settings:

Port No.	Default Group	Unmatched VID	Egress tag rule	Null VID
1	1	Disabled	4	Disabled
2	1	Disabled	4	Disabled
3	1	Disabled	4	Disabled
4	1	Disabled	4	Disabled
5	1	Disabled	4	Disabled
6	1	Disabled	4	Disabled
7	1	Disabled	4	Disabled
8	1	Disabled	4	Disabled

Enter Esc to abort..  
Please Input Ports (1~8):

Per Port Settings	Description
Ports	Input port list for configuration.
Default Group	Index to the default group of the selected ports
Unmatched VID	<p><i>Enable</i> - Drop the tagged packet if the packet's VID does not match the ingress port's PVID</p> <p><i>Disable</i> - No Unmatched VID filtering is applied to the port</p>
Egress tag rule	<p>Egress Tagging rules are used to make change to the packet before it is transmitted out from an egress port. Options are:</p> <p>(1) <i>Tagging with ingress PVID for all packets</i> -</p> <p><b>Untagged packet</b> : the packet is inserted with the associated ingress port's PVID as tag VID</p> <p><b>Tagged packet</b> : the packet's tag VID is replaced with ingress port's PVID as new tag VID</p> <p>(2) <i>Untagging for all packets</i> -</p> <p><b>Untagged packet</b> : the packet is not modified</p> <p><b>Tagged packet</b> : the packet's tag VID is removed and becomes an untagged packet</p> <p><b>Null VID packet</b> : depending on next Null VID Replacement setting</p> <p>(3) <i>Ingress PVID insertion for untagged packets only</i> -</p> <p><b>Untagged packet</b> : the packet is inserted with the associated ingress port's PVID as tag VID</p> <p><b>Tagged packet</b> : the packet is not modified</p> <p>(4) <i>No tag insertion and tag removal</i> -</p> <p>The packet is not modified at all. No tag insertion or tag removal are performed for all packets.</p>

Null VID                      The null VID of a Null VID packet will be replaced with the associated ingress port's PVID. This setting still works even Egress Tag rule : [PVID insertion for untagged packets only] is selected.

*Enable* - Null VID is replaced with Port's PVID for Null VID packets  
*Disable* - Null VID replacement rule is not applied.

---

## 4.5.2 Administrator -> QoS Settings

Select [4] Administrator -> [2] QoS Settings to configure QoS function related settings for the switch.

---

QoS Settings Menu:  
[0] Print this menu  
[1] QoS Per Port Settings  
[2] QoS Other Settings  
[Q] Back Administrator  
Please Select(0-3)

---

Select [1] QoS Per Port Settings to configure port related QoS settings:

---

QoS Per Port Settings:

Port No.	Port based priority	802.1p classification	Default TOS/DS classification
1	Disabled	Disabled	Disabled
2	Disabled	Disabled	Disabled
3	Disabled	Disabled	Disabled
4	Disabled	Disabled	Disabled
5	Disabled	Disabled	Disabled
6	Disabled	Disabled	Disabled
7	Disabled	Disabled	Disabled
8	Disabled	Disabled	Disabled

Enter Esc to abort..  
Please Input Ports (1~8):

---

---

Per Port Settings	Description
Ports	Input port list for configuration.
Port based priority	<i>Enable</i> - All packets received on the port are classified as high priority <i>Disable</i> - Port-based classification is not applied.
802.1p classification	<i>Enable</i> - Tagged packets received on the port are classified by comparing the packet's User Priority value and 802.1p High Priority Tag Setting. <i>Disable</i> - 802.1p classification is not applied.

---

Default TOS/DS classification *Enable* - If the packets DSCP value is one the default code point listed below, the packet is classified as high priority. EF - <101110>, AF - <001010> <010010> <011010> <100010> and Network Control - <111000> <110000>  
*Disable* - Default DSCP classification is not applied.

---

Select [2] *QoS Other Settings* to configure QoS global settings:

---

QoS Other Settings:  
[0] Print this menu  
[1] Show QoS Other Status  
[2] 802.1p priority tag  
[3] Egress service policy  
[4] Specific DS Settings  
[5] Specific IP Settings  
[Q] Back QoS  
Please Select(0-6)

---

Select [1] *Show QoS Other Status* to view other settings (global):

---

802.1p priority tag : 4  
Egress service policy : 16 : 1  
Specific DS(A) Setting : Disabled  
Specific DS(A) Value : 111111  
Specific DS(B) Setting : Disabled  
Specific DS(B) Value : 111111  
Specific IP(A) Setting : Disabled  
Specific IP(A) Value : 255.255.255.255  
Specific IP(A) Mask Value : 255.255.255.255  
Specific IP(B) Setting : Disabled  
Specific IP(B) Value : 255.255.255.255  
Specific IP(B) Mask Value : 255.255.255.255  
INET>

---

Select [2] - [5] to configure other settings as follows:

---

<b>QoS Other Settings</b>	<b>Description</b>
802.1p priority tag	802.1p High Priority Tag Threshold Setting for 802.1p classification Valid values : 0 - 7
Egress service policy	Weighted Round Robin ratio: (1) 4:1 - 4 high priority packets then 1 low priority packet (2) 8:1 - 8 high priority packets then 1 low priority packet (3) 16 :1 - 16 high priority packets then 1 low priority packet (4) <i>Always high first</i> - Packets in high priority queue are sent first until the queue is empty
Specific DS(A) Setting	<i>Enable</i> - Enable user defined DSCP(A) checking <i>Disable</i> - User defined DSCP(A) classification is not applied.
Specific DS(A) Value	Enter user defined DSCP(A) value for classification.
Specific DS(B) Setting	<i>Enable</i> - Enable user defined DSCP(B) checking <i>Disable</i> - User defined DSCP(B) classification is not applied.
Specific DS(B) Value	Enter user defined DSCP(B) value for classification.
Specific IP(A) Setting	If a received IP packet 's source address or destination address belongs to the user defined IP network addresses. The packet is classified as high priority.  <i>Enable</i> - Enable user defined IP(A) network address checking <i>Disable</i> - IP(A) classification is not applied.
Specific IP(A) Value	Set user defined IP(A) address for classification.
Specific IP(A) Mask Value	Set user defined IP(A) subnet mask for classification.  IP(A) address and IP(A) subnet mask specify IP(A) user defined IP network address for IP packet classification.
Specific IP(B) Setting	If a received IP packet 's source address or destination address belongs to the user defined IP network addresses. The packet is classified as high priority.  <i>Enable</i> - Enable user defined IP(B) network address checking <i>Disable</i> - IP(B) classification is not applied.
Specific IP(B) Value	Set user defined IP(B) address for classification.
Specific IP(B) Mask Value	Set user defined IP(B) subnet mask for classification.  IP(B) address and IP(B) subnet mask specify IP(B) user defined IP network address for IP packet classification.

---

### 4.5.3 Administrator -> MAC Aging Settings

Select [3] *MAC Aging Settings* to configure aging time of learned MAC addresses:

---

MAC Aging : Standard

Enter Esc to abort..

(1)Standard

(2)Fast

(3)Disable

Please Input(1/2/3):

---

MAC aging time

Standard: 200 ~ 300 seconds

Fast: 800 micro-second

Disable: The MAC is not aged out as it is learned.

### 4.5.4 Administrator -> Ping

Select [4] *Ping* to ping a IP device from the switch:

---

Ping..

Please Input Ping IP: xxx.xxx.xxx.xxx

Please Input Ping Counter(1~9): x

---

Enter the IP address of the target device and the number of Ping commands.

Example with IP 192.168.0.22 and counter 5:

---

ping 0 to 192.168.0.22:

got ping reply; len :64 seq 0 from 192.168.0.22

INET> INET>

ping 1 to 192.168.0.22:

got ping reply; len :64 seq 1 from 192.168.0.22

INET>

ping 2 to 192.168.0.22:

got ping reply; len :64 seq 2 from 192.168.0.22

INET>

ping 3 to 192.168.0.22:

got ping reply; len :64 seq 3 from 192.168.0.22

INET>

ping 4 to 192.168.0.22:

got ping reply; len :64 seq 4 from 192.168.0.22

INET>

ping complete; sent 5, received 5

INET>

---

## 4.5.5 Administrator -> ARP Table

Select [5] *ARP Table* to view the current ARP table in the switch.

Example:

---

```
ARP Table
-----
MAC Address          IP
-----
00-40-F4-FF-81-A7    192.168.0.5
00-1D-60-62-03-DD    192.168.0.51
00-40-F6-4C-41-8E    192.168.0.3
00-11-2F-91-E7-BF    192.168.0.73
00-40-F6-F4-62-6A    192.168.0.10
00-11-2F-85-A3-69    192.168.0.75
00-17-31-57-5F-7A    192.168.0.63
00-0C-6E-E3-EF-C5    192.168.0.79
00-0C-6E-62-5F-B1    192.168.0.53
00-15-F2-3E-AA-E2    192.168.0.90
00-40-F6-4C-F6-14    192.168.0.7
00-15-F2-4D-68-9B    192.168.0.89
00-40-F6-F9-03-28    192.168.0.82
00-40-F6-CC-B6-30    192.168.0.240
00-11-D8-20-12-32    192.168.0.198
00-40-F6-4C-66-42    192.168.0.22
00-40-01-29-E4-B2    192.168.0.41
00-E0-4C-39-00-55    192.168.0.76
00-0E-A6-4D-BA-CA    192.168.0.68
-----
```

---

## 4.5.6 Administrator -> WDT Settings

Select [6] *WDT Settings* to configure WDT function:

---

```
WDT Settings Menu:
[0] Print this menu
[1] WDT Status
[2] WDT Setting
[Q] Back Administrator
Please Select(0-2,Q)....
INET>

INET> 1
WDT Function Setting : Disable
WDT Time Setting(1~60sec) : 1
```

---

The switch provides WDT (Watch Dog Timer) function. If enabled, a watchdog timer is a hardware timing circuit that triggers a system reset if the switch firmware, due to some fault condition, such as a hang, neglects to regularly service the watchdog. The intention is to bring the system back from the hung state into normal operation. WDT Time Setting configures the time out of the watchdog timer.

## 4.6 Restore Default Values

Select [6] *Restore Default Values* to restore all settings of the switch back to factory default values.

---

Do you want to restore system default settings?(Y/N):

---

Refer to Appendix for factory default values.

## 4.7 Security Manager

Select [7] *Security Manager* to change user name and password. The user name and password are used for access authentication to the switch in telnet management and web management.

---

Current username: admin  
Current password: \*\*\*\*\*

Press ESC to abort ...

Change username[admin]:admin  
Enter password(1-8):\*\*\*  
Confirm password:\*\*\*  
Password updating .....  
Password updated.

---

User is requested to enter new password again for confirmation. A new password is accepted only two passwords are identical.

It is suggested to change the factory default user name and password before installing the switch into your network.

## 4.8 Update Firmware

Select *[7] Update Firmware* to update the firmware of the switch. A new firmware may be released by the factory due to function enhancement. The update method is via TFTP protocol.

The steps are:

1. A TFTP server must be available in the network before updating the firmware.
2. Place the new firmware on the TFTP server with filename [image.bin].
3. Use *[7] Update firmware* to specify the IP address of the TFTP server and start downloading of the new firmware as follows:

---

```
Enter Esc to abort..
Please Input TFTP Server IP Address(xxx.xxx.xxx.xxx):yyy.yyy.yyy.yyy
TFTP Server :yyy.yyy.yyy.yyy
Do you want to start download new image? (Y/N)
```

---

---

Setting	Description
TFTP IP Address	IP address of the TFTP server from where a new firmware is downloaded.

---

## 4.9 Reboot System

Select *[7] Reboot System* to reboot the switch.

---

```
Do you want to reboot system?(Y/N):y
Start rebooting.....
```

---

Press [Y] to confirm to reboot the switch with current configuration settings. Note that the current telnet connection will be disconnected after confirmation.

You must restart your telnet and login into the switch again.

## 4.10 Exit

Select *[Q] Exit* to stop telnet connection with the switch.

## 5. Web Management

---

The switch features an http server which can serve the management requests coming from any web browser software over internet or intranet network.

### Web Browser

Compatible web browser software with JAVA support

Microsoft Internet Explorer 4.0 or later

Netscape Communicator 4.x or later

### Set IP Address for the System Unit

Before the switch can be managed from a web browser software, make sure a unique IP address is configured for the switch.

## 5.1 Start Browser Software and Making Connection

Start your browser software and enter the IP address of the switch unit to which you want to connect. The IP address is used as URL for the browser software to search the device.

---

URL : http://xxx.xxx.xxx.xxx/

---

Factory default IP address : 192.168.0.2

## 5.2 Login to the Switch Unit

When browser software connects to the switch unit successfully, a Login screen is provided for you to login to the device as follows:

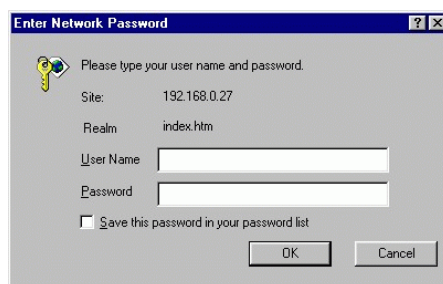

### Login

Factory default Username : Admin

Factory default Password : 123

The following screen shows welcome screen when a successful login is performed.



The screen supports the following menus on the right side:

1. Configuration: configuration control settings
2. Monitoring: view all switched port status
3. Maintenance: other management functions

## 5.3 Configuration

Click >*Configuration* to perform more advanced management functions as follows:

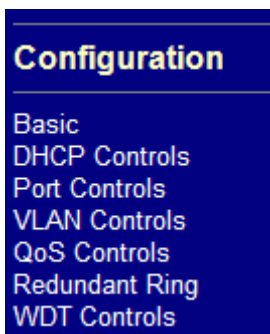

---

<b>Menu</b>	<b>Function</b>
Basic	Configure IP and SNMP settings for the switch
DHCP Controls	Configure DHCP client function for IP address
Port Controls	Change port configuration including auto-negotiation, speed, duplex
VLAN Controls	Configure VLAN related settings
QoS Controls	Configure QoS related settings
Redundant Ring	Configure Redundant Ring settings
WDT Controls	Configure WDT (Watch Dog Timer) settings

---

## 5.3.1 Basic Menu

Click *Basic* menu to configure IP settings and SNMP settings for the switch:

[ [IP Address](#) | [SNMP Entries](#) ]

The following menu options provide some basic functions to allow a user to view and modify:

IP Address, and  
SNMP Entries (Various Settings).

### IP Address

[ [IP Address](#) | [SNMP Entries](#) ]

### IP Address Settings

IP Address:	192.168.0.210
Submask:	255.255.255.0
Gateway:	192.168.0.1
Mac Address:	00 40 F6 F7 07 A3

Update Settings

---

IP Address Setting	Description
IP Address	IP address for the switch
Submask	Subnet mask of the IP address
Gateway	IP address of the default gateway
Mac Address	The MAC address of this managed switch unit

---

## SNMP Entries

SNMP settings include system settings, community settings and Snmp trap settings as follows:

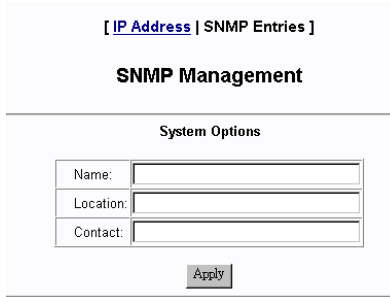

The screenshot shows a web interface for 'SNMP Management'. At the top, there is a breadcrumb trail '[ IP Address | SNMP Entries ]'. Below it is the title 'SNMP Management'. Underneath is a section titled 'System Options' containing three input fields: 'Name:', 'Location:', and 'Contact:'. An 'Apply' button is located at the bottom of the form.

---

### System Settings Description

---

Name	Set a system name for the switch
Location	Set the location where the switch unit is installed
Contact	Set the contact person for the switch unit

---

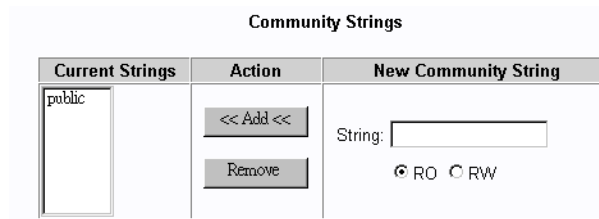

The screenshot shows the 'Community Strings' configuration interface. It features a table with three columns: 'Current Strings', 'Action', and 'New Community String'. The 'Current Strings' column contains a list box with 'public' selected. The 'Action' column has two buttons: '<< Add <<' and 'Remove'. The 'New Community String' column has a 'String:' input field and radio buttons for 'RO' (selected) and 'RW'.

---

### Community Settings Description

---

Community String	Community strings which are allowed to access the switch unit via SNMP protocol
Access Right	The access right assigned to the community string, options are: <i>RO</i> - read only <i>RW</i> - read / write
[<<Add>>]	Add one new community string specified in String box. Up to 4 community strings are allowed.
[Remove]	Remove the specified community string from list.

---

**Trap Managers**

Current Managers	Action	New Manager
<div style="border: 1px solid black; padding: 2px; min-height: 40px;">192.168.0.2</div>	<input type="button" value=" &lt;&lt; Add &lt;&lt;"/>  <input type="button" value=" Remove"/>	IP Address: <input style="width: 100%;" type="text"/> Community: <input style="width: 100%;" type="text"/>

Enable Link Change Trap  
 Enable Login Failure Trap

---

Trap Manager Settings	Description
IP Address	Specify the IP address of the trap manager to which the switch will send Snmp traps when predefined events occur.
Community	Community string used together with the trap messages sent to the trap manager
[<<Add>>]	Button to add a new trap manager (specified by an IP and Community) into manager list
[Remove]	Button to remove the trap manager
Enable Link Change Trap	Check to enable the switch to send a trap when any port link changes
Enable Login Failure Trap	Check to enable the switch to send a trap when any login failure is detected

### 5.3.2 DHCP Controls

**DHCP Controls**

Function Name	Status	Settings
DHCP Client	Disabled	<input type="radio"/> Enable <input checked="" type="radio"/> Disable
Lease Time	0 (sec)	

DHCP client function is used to get dynamic IP configuration for the switch from a DHCP server.

Settings	Description
DHCP Client	<i>Enable</i> - Enable DHCP client function for IP configuration <i>Disable</i> - disable DHCP client function
Lease Time	The time left for the lease IP address currently used

### 5.3.3 Port Controls

**Port Controls**

Port	Port Function	Auto Negotiation	Speed Control	Duplex Control
Port 1	N	N	N	N
Port 2				
Port 3				
Port 4				
<input type="button" value="Apply"/>				

Port	Link Status	Port Function	Auto Negotiation	Speed Status	Duplex Status
1	Down	Enabled	Enabled	100 M	Full
2	Down	Enabled	Enabled	100 M	Full
3	Down	Enabled	Enabled	100 M	Full
4	Down	Enabled	Enabled	100 M	Full
5	Down	Enabled	Enabled	100 M	Full
6	Up	Enabled	Enabled	100 M	Full
7	Down	Enabled	Enabled	100 M	Full
8	Down	Enabled	Enabled	100 M	Full

---

#### Port Settings

#### Description

---

Port	Specify the ports for the new settings. More than one port can be configured at the same time. Use <Shift> key and <Ctrl> key to specify multiple ports.
Port Function	Enable port transmission function, options: <i>N</i> - unchanged <i>Enable</i> - enable the port function <i>Disable</i> - disable the port function
Auto Negotiation	Enable auto negotiation function, options: <i>Null</i> - unchanged <i>Enable</i> - enable the port auto-negotiation function <i>Disable</i> - disable the port auto-negotiation function and use forced mode
Speed Control	Select port speed when auto-negotiation is disabled, options: <i>Null</i> - unchanged <i>100M</i> - 100Mbps <i>10M</i> - 10Mbps
Duplex Control	Select port duplex when auto-negotiation is disabled, options: <i>Null</i> - unchanged <i>Full</i> - full duplex <i>Half</i> - half duplex
Apply	Button to confirm the settings

---

The current port settings for all ports are also listed below the control dialog window.

### 5.3.4 VLAN Controls

VLAN settings are divided into three categories:

1. Global - Settings which are applied for the switch and not for specific ports
2. Group - Settings for VLAN groups
3. Per Port - Settings applied to each port

Global	Group	Per Port
<ul style="list-style-type: none"> <li>• VLAN</li> <li>• Ingress Rules</li> </ul>	<ul style="list-style-type: none"> <li>• Member Ports</li> <li>• VLAN ID</li> </ul>	<ul style="list-style-type: none"> <li>• Per Port Setting</li> </ul>

VLAN Select

---

Disable VLAN  
 Enable VLAN

Global	Group	Per Port
<ul style="list-style-type: none"> <li>• VLAN</li> <li>• Ingress Rules</li> </ul>	<ul style="list-style-type: none"> <li>• Member Ports</li> <li>• VLAN ID</li> </ul>	<ul style="list-style-type: none"> <li>• Per Port Setting</li> </ul>

**VLAN Other Setting**

Function Name	Status	Settings
802.1Q tag aware VLAN	Enabled	<input checked="" type="radio"/> Enable <input type="radio"/> Disable
Ingress member filtering mode	Disabled	<input type="radio"/> Enable <input checked="" type="radio"/> Disable



---

**Global Settings****Description**

---

**VLAN**

VLAN Select

*Enable VLAN* - Enable switch VLAN function  
*Disable VLAN* - disable switch VLAN function

**Ingress Rules**

802.1Q tag aware VLAN

*Enable* - Under this mode, the switch will check the content of every received packets. For 802.1Q tagged packets, the tagged VID on the packet is used to look up the VLAN group table and find the group whose VID matches the packet's tagged VID.

*Disable* - Under this mode, the switch does not check the contents of the received packets. The default VLAN group indexed by the ingress port is used directly for further VLAN operation.

Ingress member filtering Mode

*Enable* - Drop packet if the ingress port is not the member port of the found VLAN group

*Disable* - ingress member filtering rule is not applied

---

**VLAN Group Configuration**

**Global**

- VLAN
- Ingress Rules

**Group**

- Member Ports
- VLAN ID

**Per Port**

- Per Port Setting

**VLAN Member Port Setting**

Groups	Ports							
	1	2	3	4	5	6	7	8
Group 1	N	N	N	N	N	N	N	N
Group 2								
Group 3								
Group 4								

Apply

Groups	Ports							
	1	2	3	4	5	6	7	8
1	■	■	■	■	■	■	■	■
2		■						
3			■					
4				■				
5					■			
6						■		
7							■	
8								■
9	■	■	■	■	■	■	■	■

\* Group # 9 must have one port member at least !

---

Group Settings	Description
----------------	-------------

---

Groups	Specify the VLAN group for member port configuration
Port	Specify the port to be added into or deleted from the specified group. <i>N</i> - unchanged <i>Add</i> - add the port into member port list of the group <i>Del</i> - delete the port from member list of the group
Apply	Button to confirm the settings

---

**VLAN ID Setting**

Group	1	2	3	4	5	6	7	8	9
VLAN ID	1	2	3	4	5	6	7	8	128
Settings	<input type="text"/>	<input type="text"/>	<input type="text"/>	<input type="text"/>	<input type="text"/>	<input type="text"/>	<input type="text"/>	<input type="text"/>	<input type="text"/>

---

Group Settings	Description
----------------	-------------

---

VLAN ID	Current VLAN ID (VID) of each VLAN group
Settings	Set new VLAN ID of VLAN group, valid values : 1 ~ 4095
?	Button to view information about VLAN ID
Apply	Button to confirm the settings

---

*Note:*

- 1. Group 9 is a VLAN dedicated for management security purpose and it is the default group of the management port of the switch.*
- 2. The management is allowed only through one of the port members in Group 9. Group 9 limits the ports which are allowed to access the management interfaces.*
- 3. Group 9 must have at least one port member. Otherwise, there is no chance to configure the switch again unless restoring back to factory defaults.*

## Per Port Settings

<b>Global</b>	<b>Group</b>	<b>Per Port</b>
<ul style="list-style-type: none"> <li>• VLAN</li> <li>• Ingress Rules</li> </ul>	<ul style="list-style-type: none"> <li>• Member Ports</li> <li>• VLAN ID</li> </ul>	<ul style="list-style-type: none"> <li>• Per Port Setting</li> </ul>

### VLAN Per Port Setting

Port	Ingress		Egress	
	Default Group	Unmatched VID	Egress tag rule	Null VID
Port 1 ▲	N ▼	N ▼ ?	N ▼ ?	N ▼ ?
Port 2		N		
Port 3		Enable		
Port 4 ▼		Disable	Apply	

Port	Ingress		Egress	
	Default Group	Unmatched VID	Egress tag rule	Null VID
1	1	Disabled	4	Disabled
2	1	Disabled	4	Disabled
3	1	Disabled	4	Disabled
4	1	Disabled	4	Disabled
5	1	Disabled	4	Disabled
6	1	Disabled	4	Disabled
7	1	Disabled	4	Disabled
8	1	Disabled	4	Disabled

---

## Per Port Settings

## Description

Port Select port list for configuration.

### Ingress Rules

Default Group Index to the default VLAN group of the selected ports, group 1 ~ 8

Unmatched VID *N* - unchanged

*Enable* - Drop the tagged packet if the packet VID does not match the ingress port PVID

*Disable* - No Unmatched VID filtering is applied to the port

### Egress Rules

Egress tag rule This tagging rule is used to make change to the packet before it is transmitted out from an egress port. Options are:

*N* - unchanged

*1 Tagging with ingress PVID for all packets* -

**Untagged packet** : the packet is inserted with the associated ingress port PVID as tag VID

**Tagged packet** : the packet tag VID is replaced with ingress port PVID as new tag VID

*2 Untagging for all packets -*

**Untagged packet** : the packet is not modified

**Tagged packet** : the packet tag VID is removed and becomes an untagged packet

**Null VID packet** : depending on next Null VID Replacement setting

*3 Ingress PVID insertion for untagged packets only -*

**Untagged packet** : the packet is inserted with the associated ingress port PVID as tag VID

**Tagged packet** : the packet is not modified

*4 No tag insertion and tag removal -*

The packet is not modified at all. No tag insertion or tag removal are performed for all packets.

Null VID

The null VID of a Null VID packet will be replaced with the associated ingress port's PVID. This setting still works even Egress Tag rule : [*PVID insertion for untagged packets only*] is selected.

*N* - unchanged

*Enable* - Null VID is replaced with Port's PVID for Null VID packets

*Disable* - Null VID replacement rule is not applied.

?

Button to view more information about the associated setting

[Apply]

Button to confirm the settings

---

## 5.3.5 QoS Controls

QoS settings are divided into two categories:

1. Per Port Settings - QoS settings for each port
2. Other Settings - Some global QoS settings

- QoS Functions**

  - Per Port Settings
  - Other Settings

### QoS Per Port Settings

Port	Port based priority	802.1p classification	TOS/DS classification
Port 1	N	N	N
Port 2			
Port 3			
Port 4			
[Apply]			

Port	Port based priority	802.1p classification	TOS/DS classification
1	Disabled	Disabled	Disabled
2	Disabled	Disabled	Disabled
3	Disabled	Disabled	Disabled
4	Disabled	Disabled	Disabled
5	Disabled	Disabled	Disabled
6	Disabled	Disabled	Disabled
7	Disabled	Disabled	Disabled
8	Disabled	Disabled	Disabled

---

### QoS Per Port Settings Description

---

Port	Select port list for the per port QoS configuration.
Port based priority	Port based priority classification <i>Enable</i> - All packets received on the port are classified as high priority <i>Disable</i> - Port-based classification is not applied. <i>N</i> - unchanged
802.1p classification	<i>Enable</i> - Tagged packets received on the port are classified by comparing the packet's User Priority value and 802.1p High Priority Tag Setting. <i>Disable</i> - 802.1p classification is not applied. <i>N</i> - unchanged
TOS/DS classification	<i>Enable</i> - If the packets DSCP value is one the default code point listed below, the packet is classified as high priority. EF - <101110>, AF - <001010> <010010> <011010> <100010> and Network Control - <111000> <110000> <i>Disable</i> - Default DSCP classification is not applied. <i>N</i> - unchanged
[Apply]	Button to confirm settings.

---

**QoS Functions**

- Per Port Settings
- Other Settings

**QoS Other Settings**

Function Name	Status	Settings
802.1p priority tag high priority threshold	4	4
Egress service policy	16 : 1	16 : 1
Specific DSCP (A)	Disabled	<input type="radio"/> Enable <input checked="" type="radio"/> Disable 111111
Specific DSCP (B)	Disabled	<input type="radio"/> Enable <input checked="" type="radio"/> Disable 111111
Specific IP & Mask (A)	Disabled	<input type="radio"/> Enable <input checked="" type="radio"/> Disable IP: 255.255.255.255 Mask: 255.255.255.255
Specific IP & Mask (B)	Disabled	<input type="radio"/> Enable <input checked="" type="radio"/> Disable IP: 255.255.255.255 Mask: 255.255.255.255

Apply

**QoS Global Settings**

**Description**

802.1p high priority threshold	802.1p High Priority Tag Setting for 802.1p classification Valid values : 0 - 7
Egress service policy	Weighted Round Robin ratio: 4:1 - 4 high priority packets then 1 low priority packet 8:1 - 8 high priority packets then 1 low priority packet 16 : 1 - 16 high priority packets then 1 low priority packet <i>Always high first</i> - Packets in high priority queue are sent first until the queue is empty
Specific DSCP(A)	<i>Enable</i> - Enable user defined DSCP(A) checking <i>Disable</i> - DSCP(A) classification is not applied.
Specific DSCP(A) Value	Enter user defined DSCP(A) value for classification.
Specific DSCP(B)	<i>Enable</i> - Enable user defined DSCP(B) checking <i>Disable</i> - DSCP(B) classification is not applied.
Specific DSCP(B) Value	Enter user defined DSCP(B) value for classification.
Specific IP & Mask (A)	If a received IP packet's source address or destination address belongs to the user defined IP network addresses. The packet is classified as high priority.  <i>Enable</i> - Enable user defined IP(A) network address checking <i>Disable</i> - IP(A) classification is not applied.
Specific IP Address (A)	Enter user defined IP(A) address for classification.
Specific Mask (A)	Enter user defined IP(A) subnet mask for classification.

	IP(A) address and IP(A) subnet mask specify IP(A) user defined IP network address for IP packet classification.
Specific IP & Mask (B)	If a received IP packet's source address or destination address belongs to the user defined IP network addresses. The packet is classified as high priority.  <i>Enable</i> - Enable user defined IP(B) network address checking <i>Disable</i> - IP(B) classification is not applied.
Specific IP Address (B)	Enter user defined IP(B) address for classification.
Specific Mask (B)	Enter user defined IP(B) subnet mask for classification.  IP(B) address and IP(B) subnet mask specify IP(B) user defined IP network address for IP packet classification.
[Apply]	Button to confirm the settings

---

A received packet on an ingress port is classified as high priority if it meets one the following classifications:

1. The ingress port is enabled for port based high priority.
2. The ingress port is enabled for 802.1p classification and the packet is 802.1Q tagged with a tag value equal to or higher than **802.1p high priority tag threshold** setting.
3. The ingress port is enabled for Default TOS/DS classification and the packet is an IP packet with DSCP value <101110>, <001010>, <010010>, <011010>, <100010>, <111000> or <110000>.
4. Specific DSCP(A) classification is enabled and the packet is an IP packet with DSCP value matched **Specific DSCP(A)** setting.
5. Specific DSCP(B) classification is enabled and the packet is an IP packet with DSCP value matched **Specific DSCP(B)** setting.
6. Specific IP & Mask (A) classification is enabled and the packet is an IP packet whose source or destination address belong to the network address specified by **Specific IP & Mask (A)** settings.
7. Specific IP & Mask (B) classification is enabled and the packet is an IP packet whose source or destination address belong to the network address specified by **Specific IP & Mask (B)** settings.

If none of above classifications is matched, the received packet is classified as low priority. It is suggested to enable those classifications which are required for your application only and disable the rest.

### 5.3.6 Redundant Ring

Before configuring, refer to section 3.3 first for the operation of a ring network.

**Redundant Ring Ver 1.03**

Port	Settings				Ring ID
Port 1 ▼	<input checked="" type="radio"/> Null	<input type="radio"/> Ring Port	<input type="radio"/> Backup Port	<input type="radio"/> Disable Port	0
Port 2 ▼	<input checked="" type="radio"/> Null	<input type="radio"/> Ring Port	<input type="radio"/> Backup Port	<input type="radio"/> Disable Port	

<b>Auto Recovering</b>	Disabled ← ▼
------------------------	--------------

**Port Status**

Ring Status	No.	Port	Link Status	Control	Ring ID
INACTIVE	1	Null	Up	Null	0
INACTIVE	2	Null	Down	Null	

The settings below are used to specify the ring ports and backup port for the ring units and master unit:

Port Settings	Description
Port	Select two ports for cascaded connection to other switches
Port Function	Set the port function in a ring network <i>Null</i> - click to disable the port from link fault monitoring <i>Ring Port</i> - standard connected port in a ring except backup port <i>Backup Port</i> - the port connected backup link in the master switch <i>Disable Port</i> - the port is disabled for transmission operation  <i>Note : specify two ring ports for a ring member switch and specify one ring (or null) port and one backup port for the master switch.</i>
Auto Recovering	Enable <i>Auto Recover</i> feature. When enabled, the master switch monitors whether the ring network is recovered from a fault or not every minute. If the fault is fixed, the backup port is changed back to <i>Standby</i> mode.
Ring ID	Specify the ring ID of the redundant ring the switch connected. Value: 0~255.
[Apply]	Button to confirm the settings

Refer to section 5.3.6.1 for information about [Recover], [Standby] and [Inactive] buttons.

Ring & Port Status	Description
Ring Status	Display the current status in a redundant ring operation <i>STANDBY</i> - the ring is under fault monitoring (on guard) <i>BACKUP</i> - the backup link is activated and ring enters into backup state
Port No.	The port number of two connected ports for ring connection
Port	The port function of the specified ports (See port function setting above) <i>Ring</i> - the port function is a ring port <i>Backup</i> - the port function is a backup port
Link Status	The physical port link status of the connected port <i>Up</i> - the link is up <i>Down</i> - the link is down
Control	The port TX/RX is disabled or enabled. <i>Enabled</i> - the port operation is enabled <i>Disabled</i> - the port operation is disabled <i>Standby</i> - the port operation is disabled now but in standby state <i>Activated!</i> - the port operation is enabled now and backup activated state
[Ring List]	Button to display all found member switches and their status in a ring

It is useful to use [Ring List] button to examine the planned ring after configuration.

### Ring List

No.	MAC Address	Ring Status	First Port				Second Port			
			Port	Set	Link	Control	Port	Set	Link	Control
1	00 40 63 80 00 30	STANDBY	7	Ring	Up	Enabled	8	Ring	Up	Enabled
2	00 40 63 80 00 31	STANDBY	7	Ring	Up	Enabled	8	Backup	Down	Standby
3	00 40 63 80 00 32	STANDBY	7	Ring	Up	Enabled	8	Ring	Up	Enabled
4	00 40 63 80 00 33	STANDBY	7	Ring	Up	Enabled	8	Null	Down	Null

Reload Back

---

<b>Ring &amp; Port Status</b>	<b>Description</b>
MAC Address	The MAC address of the switch found in a ring
Ring Status	The ring status of the switch in
First Port	The specified 1st port of the switch for the ring connection
First Port / Port	The port number of the specified 1st port
First Port / Set	The port ring function of the specified 1st port <i>Ring</i> - the port function is a ring port <i>Backup</i> - the port function is a backup port
First Port / Link	The port link status of the specified 1st port in a ring <i>Up</i> - the link is up <i>Down</i> - the link is down
First Port / Control	The port TX/RX is disabled or enabled. <i>Enabled</i> - the port operation is enabled <i>Disabled</i> - the port operation is disabled <i>Standby</i> - the port operation is disabled now but in standby state <i>Activated!</i> - the port operation is enabled now and backup activated state
Second Port	The specified 2nd port of the switch for the ring connection
Second Port / Port	The port number of the specified 2nd port
Second Port / Set	The port ring function of the specified 2nd port <i>Ring</i> - the port function is a ring port <i>Backup</i> - the port function is a backup port
Second Port / Link	The port link status of the specified 2nd port in a ring <i>Up</i> - the link is up <i>Down</i> - the link is down
Second Port / Control	The port TX/RX is disabled or enabled. <i>Enabled</i> - the port operation is enabled <i>Disabled</i> - the port operation is disabled <i>Standby</i> - the port operation is disabled now but in standby state <i>Activated!</i> - the port operation is enabled now and backup activated state
Ring ID	The current redundant ring the switch connected
[Reload]	Button to examine the ring list again
[Back]	Button to return to previous page

---

Note: More than one redundant rings can be configured with the switches within a LAN in same collision domain. Each ring must be assigned an unique ring ID.

When the standby backup link is activated, the port status display is:

Port Status				
Ring Status	No.	Port	Link Status	Control
BACKUP	7	Ring	Down	Disabled
BACKUP	8	Backup	Up	Activated!

Ring List

[Ring List] can also be used to display the whole ring status upon fault as example illustrated below:

Ring List											
No.	MAC Address	Ring Status	First Port				Second Port				
			Port	Set	Link	Control	Port	Set	Link	Control	
1	00 40 63 80 00 30	BACKUP	7	Ring	Down	Disabled	8	Ring	Up	Enabled	
2	00 40 63 80 00 31	BACKUP	7	Ring	Down	Disabled	8	Backup	Up	Activated!	
3	00 40 63 80 00 32	BACKUP	7	Ring	Up	Enabled	8	Ring	Up	Enabled	
4	00 40 63 80 00 33	BACKUP	7	Ring	Up	Enabled	8	Null	Up	Null	

Reload Back

The backup link is activated and the ring is using backup link and in backup status now. The fault is caused by the cable connected on Switch 1 Port 7 and Switch 2 Port 7.

### 5.3.6.1 Fault Repairing & Ring Checking

After repairing the network fault, the following buttons can be used in master switch to recover the ring function back to standby state:

Redundant Ring Ver 1.01				
Port	Settings			
Port 7	<input type="radio"/> Null	<input checked="" type="radio"/> Ring Port	<input type="radio"/> Backup Port	<input type="radio"/> Disable Port
Port 8	<input type="radio"/> Null	<input type="radio"/> Ring Port	<input checked="" type="radio"/> Backup Port	<input type="radio"/> Disable Port

Apply Recover Standby Inactive

Button	Description
[Apply]	Button to save the configuration
[Recover]	Button to release blocked switches and failed section after network fault repairing  <i>Note : it may not recover the whole failed section by just one click especially in the case when multiple faults occur at the same time. Click and use [Ring List] button to display ring status until the recovery is complete.</i>
[Standby]	Button to instruct all ring members enters into standby state (on guard) for fault monitoring after ring list shows everything is back to normal
[Inactive]	Button to relieve the backup port function of the master switch

### Ring List

No.	MAC Address	Ring Status	First Port				Second Port			
			Port	Set	Link	Control	Port	Set	Link	Control
1	00 40 63 80 00 30	STANDBY	7	Ring	Up	Enabled	8	Ring	Up	Enabled
2	00 40 63 80 00 31	STANDBY	7	Ring	Up	Enabled	8	Backup	Down	Standby
3	00 40 63 80 00 32	STANDBY	7	Ring	Up	Enabled	8	Ring	Up	Enabled
4	00 40 63 80 00 33	STANDBY	7	Ring	Up	Enabled	8	Null	Down	Null

Reload Back

If *Auto Recovering* is enabled and ring is under backup state, the ring master will monitor the ring status every minute and try to recover the ring back to standby state automatically if the ring fault is repaired.

### 5.3.7 WDT Controls

The switch provides WDT (Watch Dog Timer) function. If enabled, A watchdog timer is a hardware timing circuit that triggers a system reset if the switch firmware, due to some fault condition, such as a hang, neglects to regularly service the watchdog. The intention is to bring the system back from the hung state into normal operation.

Function Name	Status	Settings
WDT Function Setting	Disabled	<input type="radio"/> Enable <input checked="" type="radio"/> Disable
WDT Time Setting(1~60sec)	1	1

Apply

Setting	Description
WDT Function Setting	Enable or disable WDT function
WDT Time Setting (1~60sec)	Watch Dog timer configuration

### 5.4. Port Status

**Monitoring**

Port Status

Port	Type	Link Status	Auto Negotiation	Speed Status	Duplex Status
1	TP	Down	--	--	--
2	TP	Down	--	--	--
3	TP	Down	--	--	--
4	TP	Down	--	--	--
5	TP	Down	--	--	--
6	TP	Up	Enabled	100 M	Full
7	TP	Down	--	--	--
8	TP	Down	--	--	--

Port Status	Description
Port Number	1 - 6 : 10/100TX ports - P1 ~ P2 7 - 8 : 100FX ports - F1 F2
Type	Port media type TP - 10/100TX FX - 100FX (for Port 7 and Port 8 only)

Link Status	Port link status <i>Up</i> - port link up (an active link is established with a link partner) <i>Down</i> - port link down
AutoNegotiation	Auto negotiation mode status <i>Enabled</i> - auto negotiation mode is enabled <i>Disabled</i> - auto negotiation mode is disabled (forced mode)
Speed Status	Port speed status <i>100M</i> - 100Mbps <i>10M</i> - 10Mbps
Duplex Status	Port duplex status <i>Full</i> - full duplex <i>Half</i> - half duplex

---

## 5.5 Maintenance



## 5.5.1 Security Manager

This menu is used to change the user name and password. User name and password are used for access login in telnet and web management interfaces of the switch.

**Security Manager**

---

User Name:	admin
Assign/Change password:	***
Reconfirm password:	***

Settings	Description
User Name	New user name
Assign/Change password	New password
Reconfirm password	Retype the new password

## 5.5.2 Update Firmware

This menu is used to perform firmware (switch software) upgrade via TFTP protocol. Before doing TFTP operation, one TFTP server must be available in the network to where this switch is connected and the new firmware file **image.bin** is placed in the server.

**TFTP Download New Image**

---

TFTP Server IP Address	192.168.0.3
Firmware File Name	image.bin

Settings	Description
TFTP Server IP Address	Specify the IP address of the TFTP server
Firmware File Name	Specify the file name of the new firmware
[Apply]	Button to confirm the settings

### 5.5.3 Restore Default

**Do you want to restore system default settings?**

---

This menu is used to restore all settings of the switch with factory default values. Note that this menu might change the current IP address of the switch and make your current http connection lost.

### 5.5.4 Reboot System

**Are you sure to reboot system?**

---

This menu is used to reboot the switch unit with current configuration remotely. Starting this menu will make your current http connection lost. You must rebuild the connection to perform any management operation to the unit.

## 6. SNMP Management

---

The switch supports SNMP v1 protocol for SNMP management. One device MIB file is provided in the product CD. The MIB file is used for SNMP management software to set or get the management information objects provided in the switch.

### 6.1 MIB Objects

The device private management objects provided by the SNMP agent in the switch are:

---

Objects	OID	Description
Enterprise	867	Manufacturer ID
Device	37	Device ID (Snmp agent)
Software	867.37.1.1	Device firmware version
	867.37.1.2	MIB version supported
Port Status	867.37.4.1	Port status information including: Link, Auto-negotiation, speed, duplex
Port Control	867.37.4.2	Port control information including: Port function, auto-negotiation, speed, duplex
VLAN	867.37.5	VLAN function related status and control objects
QoS	867.37.6	QoS function related status and control objects

---

### 6.2 SNMP Traps

In addition to the MIB, the switch also provides SNMP trap function for sending associated trap messages to trap managers when the predefined events are detected. The following trap events are supported:

---

Trap Event	Description
Cold Start	The switch is powered on and complete initialization
Login failure	Telnet and web authentication failure
Port link change	Any port link change among the switched ports - Port link down to link up - Port link up to link down

---

The *Login failure* trap and *port link change* trap can be disabled individually. The trap manager settings must also be properly configured to make the trap function works. Refer to *Trap Manager* menu in telnet management interface and *Administrator->Basic* menu in web management interface.

# Appendix. Factory Default Settings

---

## IP Settings

---

IP Address	192.168.0.2
IP Subnet mask	255.255.255.0
Gateway IP	192.168.0.1
DHCP client	Disabled

## Security Manager Settings

---

User name	admin
Password	123

## SNMP Settings

---

System name	Null
System location	Null
System contact	Null
Community string 1	Public, Access right - read only
Community string 2-4	Null
Trap manager 1-3 IP	Null
Trap manager 1-3 Community	Null
Login failure trap	Enabled
Port link change trap	Enabled

## Port Control Settings

---

Port 1 - 8 Port function	Enabled
Port 1 - 6 Auto-negotiation	Enabled
Port 1 - 8 Port speed	100Mbps
Port 1 - 8 Port duplex	Full

## VLAN Settings

---

VLAN function	Disabled
802.1Q tag aware VLAN	Disabled
Ingress member filtering	Disabled
VLAN group 1	member : P1 - P8, VID : 1
VLAN group 2	member : P2, VID : 2
VLAN group 3	member : P3, VID : 3
VLAN group 4	member : P4, VID : 4

VLAN group 5	member : P5, VID : 5
VLAN group 6	member : P6, VID : 6
VLAN group 7	member : P7, VID : 7
VLAN group 8	member : P8, VID : 8
VLAN group 9	member : P1 - P8, VID : 128
Default VLAN group index	1 (group 1) for Port 1 - Port 8, 9 (group 9) for management port
Unmatched VID	Disabled for Port 1 - Port 8
Egress tag rule	4 for Port 1 - Port 8
Null VID replacement	Disabled for Port 1 - Port 8

### **QoS Settings**

---

Port based priority	Disabled for Port 1 - Port 8
802.1p classification	Disabled for Port 1 - Port 8
Default TOS/DS classification	Disabled for Port 1 - Port 8
802.1p high priority threshold	4
Egress service policy	16:1
Specific DSCP (A)	Disabled
Specific DSCP (A) setting	111111
Specific DSCP (B)	Disabled
Specific DSCP (B) setting	111111
Specific IP & Mask (A)	Disabled
Specific IP address (A)	255.255.255.255
Specific IP mask (A)	255.255.255.255
Specific IP & Mask (B)	Disabled
Specific IP address (B)	255.255.255.255
Specific IP mask (B)	255.255.255.255

### **Redundant Ring Settings**

---

The 1st connected port	Port 1, Null
The 2nd connected port	Port 2, Null
Auto Recovering	Disabled

### **WDT Settings**

---

WDT Function	Disable
WDT Time	1 sec.