



# KGS-612F



## Web Smart 6-Port Gigabit Ethernet Switch with 2 FE & 1 GbE SFP Ports

### Product Highlights:

- Compact design
- Web management
- Two 100M SFP fiber
- One 1000M SFP fiber
- 802.1Q Tagged VLAN support
- QoS WFQ support
- Port mirroring function
- 802.1x port access control
- 802.1w RSTP, MSTP
- LACP link aggregation
- SFP DDM support

### Key Features:

- Provides 6 10/100/1000Mbps RJ-45, one 1000M SFP and two 100M SFPs
- Provides in-band web-based management interface
- All copper ports support auto-negotiation and auto-MDI/MDI-X detection
- Provides full wire speed forwarding
- Supports 802.3x flow control for full-duplex and backpressure for half-duplex
- Provides port status, statistic monitoring and control function
- Supports port-based and 802.1Q Tag-based VLAN
- Provides QoS function
- Provides port link aggregation (trunking) function with LACP support
- Provides port mirroring function
- Provides 802.1x authentication for port access
- Supports 802.1w RSTP and MSTP
- Watchdog timer function
- Supports SFP with Digital Diagnostic Monitoring (DDM)

### Specifications:

Standard	IEEE 802.3, 802.3u, 802.3ab, 802.3x, 802.1w, 802.1x, 802.3ad, 802.1Q
Network Ports	3 10/100/1000Mbps Gigabit copper ports 2 combo ports - 10/100/1000Mbps copper & 100Base-FX SFP 1 combo port - 10/100/1000Mbps copper & 1000Base-X SFP
Copper Port	Shielded RJ-45, 10/100/1000M, auto-negotiation, auto-MDI/MDI-X support
100Base-FX SFP	Fast Ethernet 100Base-FX compliant SFP connector
1000Base-X SFP	Gigabit Ethernet 1000Base-X compliant SFP connector
Network Cables	10/100Mbps: Cat.5 up to 100m 1000Mbps: Cat.5e or higher up to 100m
MAC Address Table	8K entries, Buffer Memory: 112KB
VLAN	Port based VLAN, 8021Q Tag-based VLAN
Port Link Aggregation	Trunking groups: 4 max., Ports/group: 5, LACP (802.3ad) support
QoS	4 priority queues, Classification: Port-based, 802.1p, IP DSCP
LED Indication	Per unit: Power Per port: 1000M,100M, 10M speed/link/activity status
Management Support	Web browser software, SNMP
Management Objects	System settings, port status/statistics, port control, VLAN, QoS, Link aggregation, Port mirroring, Firmware upgrade, 802.1w RSTP, 802.1x, Configuration backup and restore, SFP DDM
Environment	Operating Temperature: 0°C ~ 40°C Storage Temperature: -20°C ~ 85°C Relative Humidity: 10% ~ 90% non-condensing

DIN-Rail Mounting



Panel Mounting



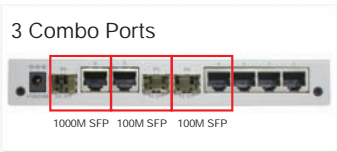

Dimension	180 x 114.5 x 26 mm (WxDxH)
Mounting	Desktop, Wall, Optional DIN-Rail & Panel Mounting
DC Power Input	DC jack: -D 6.3mm/+D 2.0mm Operating voltage range: +7 ~ +30VDC Power Consumption: 9W max.
Approval	FCC Class A, CE mark Class A

### Application 1

Edge workgroup switch with uplink to backbone via 1000M fiber

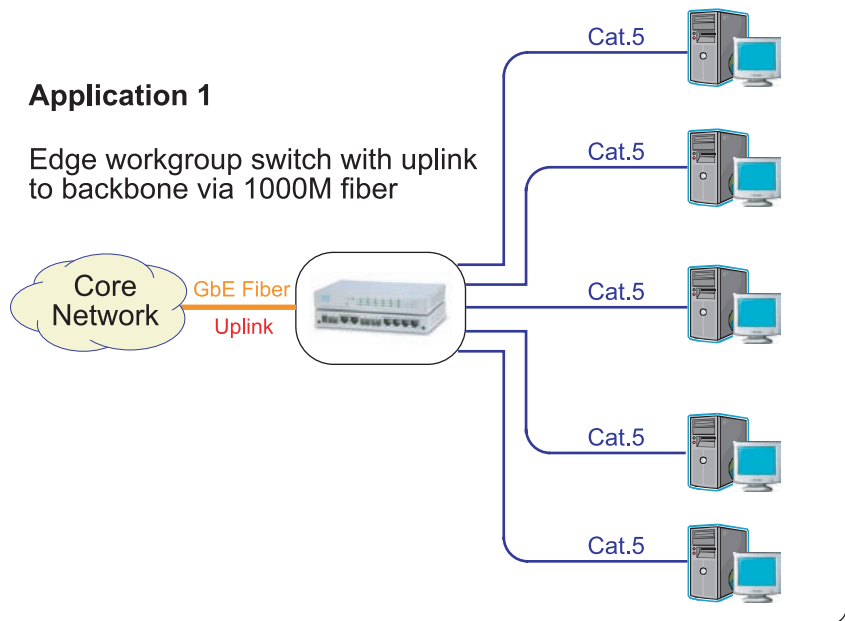

### Application 2

Workgroup switch supporting two 100M fiber connections and uplink to backbone via 1000M fiber

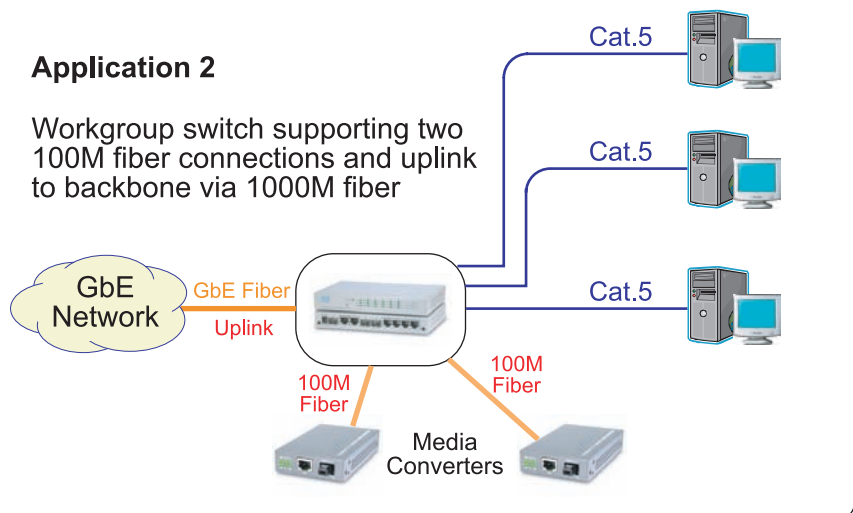

FCC Part 15, Class A  
CISPR 22 Class A

#### Katron Technologies Inc.

15F-7, No. 79, Sec. 1, Hsin Tai Wu Rd.,  
Hsi-chih, New Taipei City, Taiwan, R.O.C.  
Tel: 886-2-2698-3878  
Fax: 886-2-2698-3873  
E-mail: [kti@ktinet.com.tw](mailto:kti@ktinet.com.tw)  
URL: <http://www.ktinet.com.tw>

#### KTI Networks Inc.

10415-A Westpark Drive, Houston,  
TX 77042. U.S.A.  
Tel: 1-713-266-3891  
Fax: 1-713-914-0555  
E-mail: [contact@ktinet.com](mailto:contact@ktinet.com)  
URL: <http://www.ktinet.com>

Trademarks: All brand names are trademarks or registered trademarks of their respective holders.  
This information is subject to change without prior notice.