



KGS-0820



Managed 8-Port L2 Gigabit Ethernet Switches with 2 SFP Slots and PoE options

Product Highlights:

- 802.1Q Tagged VLAN
- QoS WFQ support
- LACP link aggregation
- 802.1x access control
- 802.1w RSTP, STP, MSTP
- DHCP client
- Two speed SFP support
- SFP DDM support
- Port mirroring
- PoE PSE option
- DC power input option

Key Features:

- Provides 8 10/100/1000Mbps RJ-45, one 100M SFP slot and one 1000M SFP slot
- Provides in-band web and SNMP management interface
- All copper ports support auto-negotiation and auto-MDI/MDI-X detection
- Two SFP slots support 100BASE-FX and 1000BASE-X SFP transceivers
- Provides Gigabit full wire speed forwarding
- Supports 802.3x flow control for full-duplex and backpressure for half-duplex
- Provides port status, statistic monitoring and control function
- Supports port-based and 802.1Q Tag-based VLAN
- Provides QoS function
- Provides port link aggregation (trunk) function with LACP support
- Provides port mirroring function
- Provides 802.1x authentication for port access
- Supports 802.1w RSTP, 8021D STP and MSTP
- Watchdog timer function
- Supports DHCP for dynamic IP configuration
- Provides optional 8 PoE (Power over Ethernet) PSE ports
- 19" rack mountable

SFP Slots

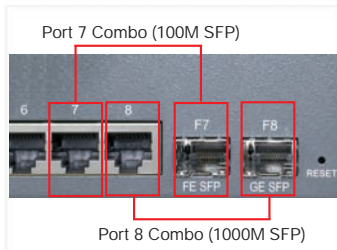

DC Power Option



Specifications:

Standard	IEEE 802.3, 802.3ab, 802.3z, 802.3x, 802.3af, 802.1x, 802.1w, 802.1D, 802.1Q
Network Ports	6 10/100/1000Mbps Gigabit copper ports 1 combo port - 10/100/1000Mbps copper & 100M fiber SFP 1 combo port - 10/100/1000Mbps copper & 1000M fiber SFP
Copper Ports	Shielded RJ-45, 10/100/1000Mbps, auto-negotiation, auto-MDI/MDI-X support
SFP Slots	One 100M SFP connector for 100M SFP fiber transceiver modules One 1000M SFP connector for 1000M SFP fiber transceiver modules DDM support
Network Cables	10/100/1000Mbps copper: Cat.5 up to 100m, 100Base-FX, 1000Base-X: 62.5/125µm, 50/125µm MM fiber, 9/125µm SM fiber
MAC Addresses	Table with 8K entries
VLAN Function	Port based VLAN, 802.1Q Tag-based VLAN
Port Link Aggregation	Static trunking groups: 2 max., Ports/group: 2, LACP link aggregation
QoS Function	4 priority queues, Classification: Port-based, 802.1p, IP DSCP
Power over Ethernet	IEEE 802.3af compliant, PSE on Port 1 ~ Port 8 (optional) Power delivery 48V 15.4W max. at port output for a Cat.5 distance of 100 meters
LED Indication	Per unit: Power, Mngt Per port: 100M, 100M/10M speed/link/activity status Per PSE port: PoE status
Web Management	Web browser software System settings, port status/statistics, port control, VLAN, QoS, Link aggregation, port mirroring, Firmware upgrade 802.1x, 802.1w, Configuration backup and restore



Ordering Informations:

Model	Managed	PoE	Power
KGS-0820-P	v	v	AC100-240V
KGS-0820-D	v	v	DC44-57V
KGS-0820-S	v	-	AC100-240V
KGS-0820-L	-	-	AC100-240V

Optional Accessories:

KTI 100M SFP fiber transceivers
KTI 1000M SFP fiber transceivers

SNMP Support	SNMP v1, v2c management, MIB-II, Event traps
AC Power Input	IEC320 receptacle, Operating voltage range: +100 ~ 240VAC
DC Power Input	Screw type terminal block Voltage range with PoE option: +44 ~ +54VDC Voltage range with no PoE: +36 ~ +57VDC
Power Consumption	AC: 16W max. (No PoE), 150W max. (PoE) @110VAC DC: 10W max. (No PoE), 133W max. (PoE) @48VDC
Housing	Enclosed metal
Dimension	295 x 160 x 43 mm (WxDxH)
Mounting Support	19" rack mountable
Environment	Operating Temperature: -5°C ~ 50°C Storage Temperature: -20°C ~ 85°C Relative Humidity: 10% ~ 90% non-condensing
Approval	FCC Class A, CE mark Class A, IEC60950 safety

Applications:

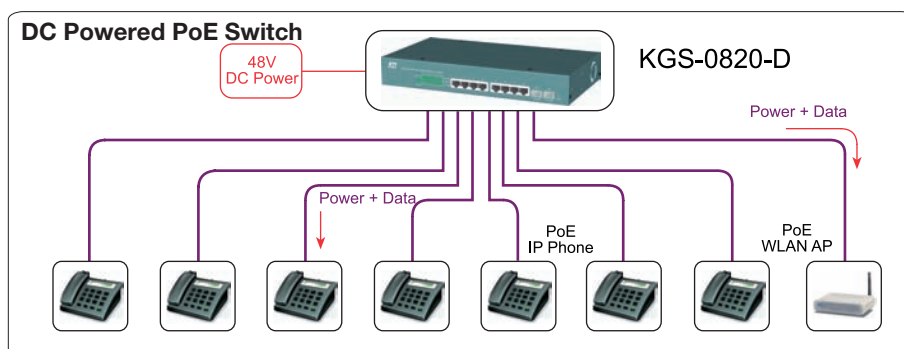
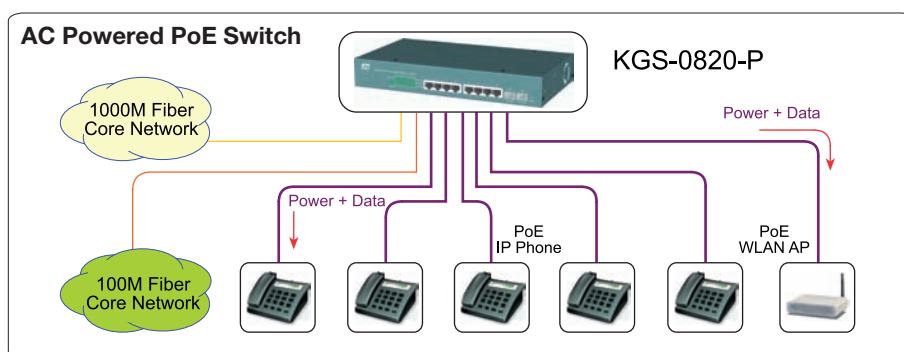
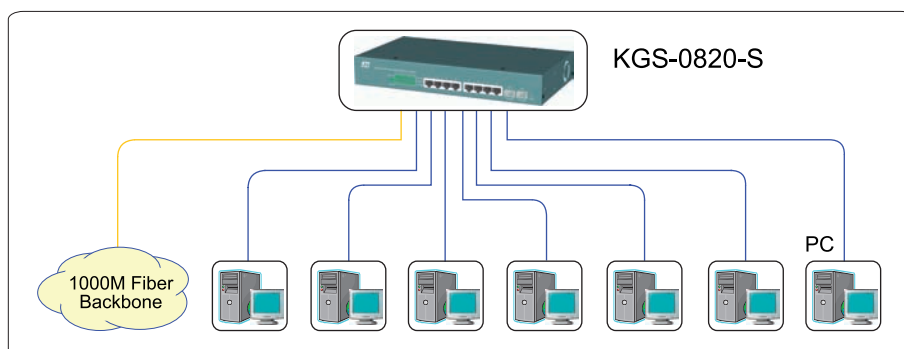

FCC Part 15, Class A
CISPR 22 Class A

Katron Technologies Inc.

15F-7, No. 79, Sec. 1, Hsin Tai Wu Rd.,
Hsi-chih District, New Taipei City, Taiwan
Tel: 886-2-2698-3878
Fax: 886-2-2698-3873
E-mail: kti@ktinet.com.tw
URL: http://www.ktinet.com.tw

KTI Networks Inc.

10415-A Westpark Drive, Houston,
TX 77042, U.S.A.
Tel: 1-713-266-3891
Fax: 1-713-914-0555
E-mail: contact@ktinet.com
URL: http://www.ktinet.com

Trademarks: All brand names are trademarks or registered trademarks of their respective holders.
This information is subject to change without prior notice.