



KGC-352



PoE-PD-enabled 1000Base-T to 1000Base-X Gigabit Media Converters

Product Highlights:

- Full wire speed performance
- SFP flexibility
- Best conversion latency
- Low power consumption
- Optional DIN-Rail mounting
- Options for Bi-Di communication
- Options for CWDM
- Powered by PoE, AC adapter

PoE PSE switch
KS-1080



PoE PSE mid-span injector
KPOE-100



The Gigabit media converter is designed to convert 1000Base-T signals to/from 1000Base-X fiber signals. It is used to extend the connection distance between two Gigabit Ethernet devices via fiber cable transparently with no performance degradation. With the SFP (Mini-GBIC) connector design, the media converter not only supports existing variety of multimode and single mode fibers, but also preserves the flexibility to adapt to any change of your fiber network in the future. It also supports center chassis installation with optional power redundancy and management features when a larger fiber network is required. With pre-configured fiber transceivers, the converter also can support Bi-Di WDM and CWDM fiber network applications.

Because of 802.3af compliance, the converters can draw the power via Cat.5 cable connected to a PoE PSE switch or mid-span injector. This feature makes the converter ideal for remote areas of a network without AC power outlets.

Key Features:

- Comply with IEEE 802.3ab 1000Base-T, 802.3z 1000Base-SX/LX standard
- Provide direct media conversion for Gigabit copper and Gigabit fiber
- Provide 1000Mbps conversion with a minimum and the best latency
- Support full wire speed conversion
- Support transparent conversion of any packet types with no packet length limitation
- Support auto-negotiation with link partners
- Provide link pass through between copper and fiber link
- Provide SFP on fiber port for mounting variety of fiber options
- Support optional DIN-Rail installation
- Ideal solution for multimode, short reach up to long reach single mode fiber, Bi-Di and CWDM applications
- Support being powered by PoE via Cat.5 in addition to typical AC power adapter

Specifications:

Standard	IEEE 802.3ab, 802.3z, IEEE 802.3af
Copper Port	Shielded RJ-45, 1000Mbps, Auto-negotiation capable, Auto-MDI/MDI-X
Fiber Port	SFP connector with pre-configured SFP fiber transceiver Far End Fault support
Network Cables	Copper port: Cat.5e recommended or higher up to 100m Fiber port: MMF 50/125µm, 62.5/125µm, SMF 9/125µm
LED Indication	Power status, SFP On status, Link status, Optical link status
Mounting	Desktop, Wall, DIN-Rail (optional)
Power Input	PoE via Cat.5 on RJ-45 from PSE switch or PoE mid-span injector DC jack via external AC power adapter
PoE	IEEE 802.3af PD compliant Input voltage: 36VDC ~ 57VDC via Cat.5 Power classification: Class 1 Power reception: via TP RJ-45 Pin 1,2,3,6 or Pin 4,5,7,8



DIN-Rail Mounting Bracket
A24-5002-000 (KC-3DR)



Ordering Informations:

Model	Fiber		Distance
-	No SFP Transceiver		
-SX	LC	850 50/125 62.5/125	500m 200m
-LX	LC	1310 MMF SMF	550m 10km
-LX20	LC	1310 SMF	20km
-LX30	LC	1310 SMF	30km
-LX50	LC	1550 SMF	50km
-LX70	LC	1550 SMF	70km
-W3510	LC	Tx1310 Rx1550	Bi-Di SMF 10km
-W5310	LC	Tx1550 Rx1310	Bi-Di SMF 10km
-W3520	LC	Tx1310 Rx1550	Bi-Di SMF 20km
-W5320	LC	Tx1550 Rx1310	Bi-Di SMF 20km
-W3540	LC	Tx1310 Rx1550	Bi-Di SMF 40km
-W5340	LC	Tx1550 Rx1310	Bi-Di SMF 40km
-W3410	LC	Tx1310 Rx1490	Bi-Di SMF 10km
-W4310	LC	Tx1490 Rx1310	Bi-Di SMF 10km
-W3410S	SC	Tx1310 Rx1490	Bi-Di SMF 10km
-W4310S	SC	Tx1490 Rx1310	Bi-Di SMF 10km



FCC Part 15, Class B
CISPR 22 Class B

Katron Technologies Inc.

15F-7, No. 79, Sec. 1, Hsin Tai Wu Rd.,
Hsi-chih, Taipei Hsien, Taiwan.
Tel: 886-2-2698-3878
Fax: 886-2-2698-3873
E-mail: kti@ktinet.com.tw
URL: http://www.ktinet.com.tw

KTI Networks Inc.

10415-A Westpark Drive, Houston,
TX 77042. U.S.A.
Tel: 1-713-266-3891
Fax: 1-713-914-0555
E-mail: contact@ktinet.com
URL: http://www.ktinet.com

Trademarks: All brand names are trademarks or registered trademarks of their respective holders. This information is subject to change without prior notice.

Environment	Operation Temperature: -5°C ~ 55°C Storage Temperature: -20°C ~ 85°C Relative Humidity: 5% ~ 95% non-condensing
Dimension	108 x 72.5 x 23 mm (WxDxH)
Operating Voltage	+7VDC ~ +57VDC input, consumption: 2W max.
Approval	FCC Class B, CE mark, CISPR 22 Class B, IEC60950-1 Safety

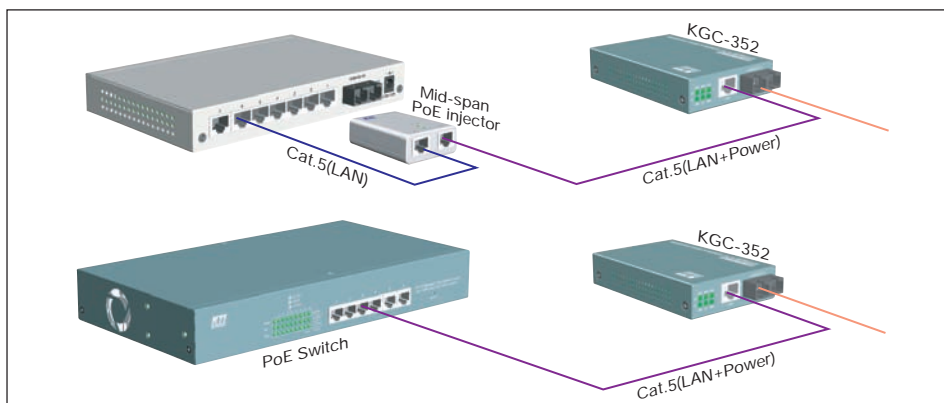

Fiber Ordering Informations:

Model	Fiber Port	Wavelength	Tx Power	Rx Sens.	Rx Max.
-SX	LC MMF	850nm	-9.5 ~ -4dBm	-18dBm	-1dBm
-LX	LC SMF	1310nm	-9.5 ~ -3dBm	-20dBm	-3dBm
-LX20	LC SMF	1310nm	-8 ~ -2dBm	-23dBm	-1dBm
-LX30	LC SMF	1310nm	-4 ~ +3dBm	-23dBm	-3dBm
-LX50	LC SMF	1550nm	-4 ~ +1dBm	-23dBm	-3dBm
-LX70	LC SMF	1550nm	0 ~ +5dBm	-23dBm	-3dBm
-W3510	Bi-Di LC SMF	Tx 1310nm Rx 1550nm	-9 ~ -3dBm	-21dBm	-3dBm
-W5310	Bi-Di LC SMF	Tx 1550nm Rx 1310nm	-9 ~ -3dBm	-21dBm	-3dBm
-W3520	Bi-Di LC SMF	Tx 1310nm Rx 1550nm	-8 ~ -3dBm	-23dBm	-3dBm
-W5320	Bi-Di LC SMF	Tx 1550nm Rx 1310nm	-8 ~ -3dBm	-23dBm	-3dBm
-W3540	Bi-Di LC SMF	Tx 1310nm Rx 1550nm	-3 ~ +2dBm	-23dBm	-1dBm
-W5340	Bi-Di LC SMF	Tx 1550nm Rx 1310nm	-3 ~ +2dBm	-23dBm	-1dBm
-W3410	Bi-Di LC SMF	Tx 1310nm Rx 1490nm	-9 ~ -3dBm	-20dBm	-3dBm
-W4310	Bi-Di LC SMF	Tx 1490nm Rx 1310nm	-9 ~ -3dBm	-20dBm	-3dBm
-W3410S	Bi-Di SC SMF	Tx 1310nm Rx 1490nm	-9 ~ -3dBm	-20dBm	-3dBm
-W4310S	Bi-Di SC SMF	Tx 1490nm Rx 1310nm	-9 ~ -3dBm	-20dBm	-3dBm

MMF: Multimode fiber -62.5/125 μm,50/125 μm
SMF: Single Mode fiber -9/125 μm