

# KFS-0540

*Industrial 5-Port Fast Ethernet Switch*



KFS-0540

# Specifications

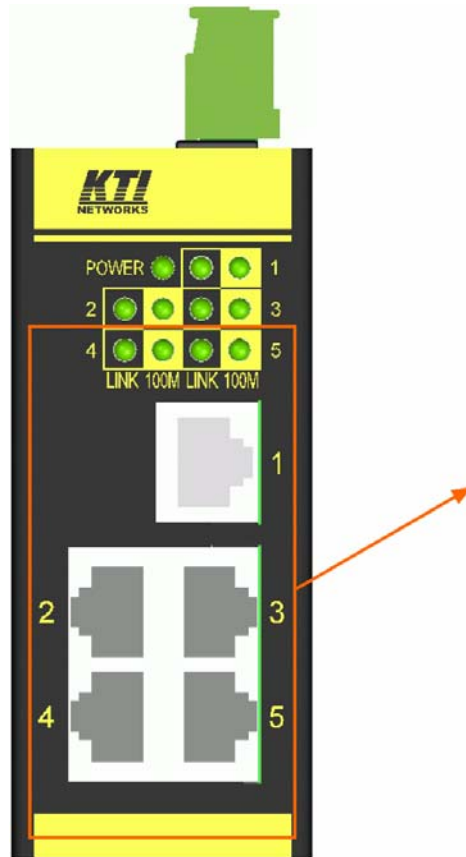

## Ports

- 5 10/100 Mbps RJ-45 support
- Auto-negotiation
- Auto-MDI/MDI-X

# Advantage : Switch Functions



## All in one Compact Box

- Full wire speed, Store and forward
- IEEE 802.3x flow control
- Storm control
- Max. packet length 1536 bytes

# Benefit 1: Power Interfaces

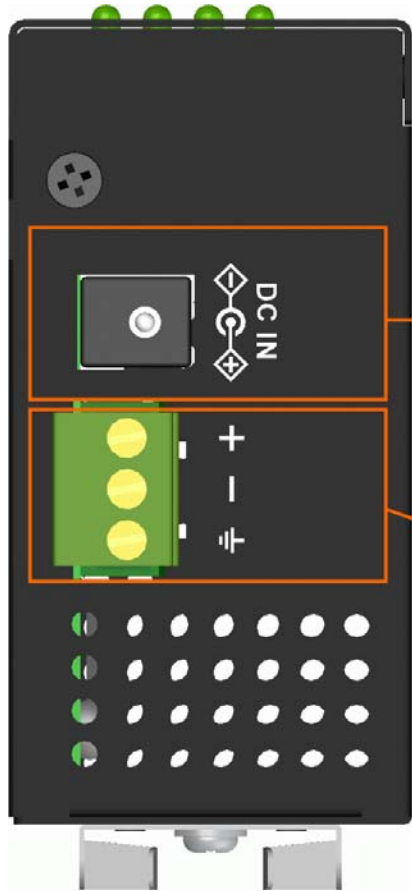

## DC-Jack

Support AC-DC adapter type power

## Terminal block

Support industrial power system

# Benefit 2: Mounting Flexibility

Din-Rail Mounting



Panel Mounting



# Benefit 3: Industrial Design

## Wide Operating Temperature Range

Typical -10°C ~ 70°C

## Wide Operating Voltage Range

+7 ~ +30VDC

## Industrial Power Interfaces

Industrial screw terminal block and DC-Jack

## Industrial Mounting Support

Din-rail mounting, Panel mounting, Desktop mounting

## EMC & EMI

Industrial-rated Emission and Immunity performance

# Application : Workgroup Switch

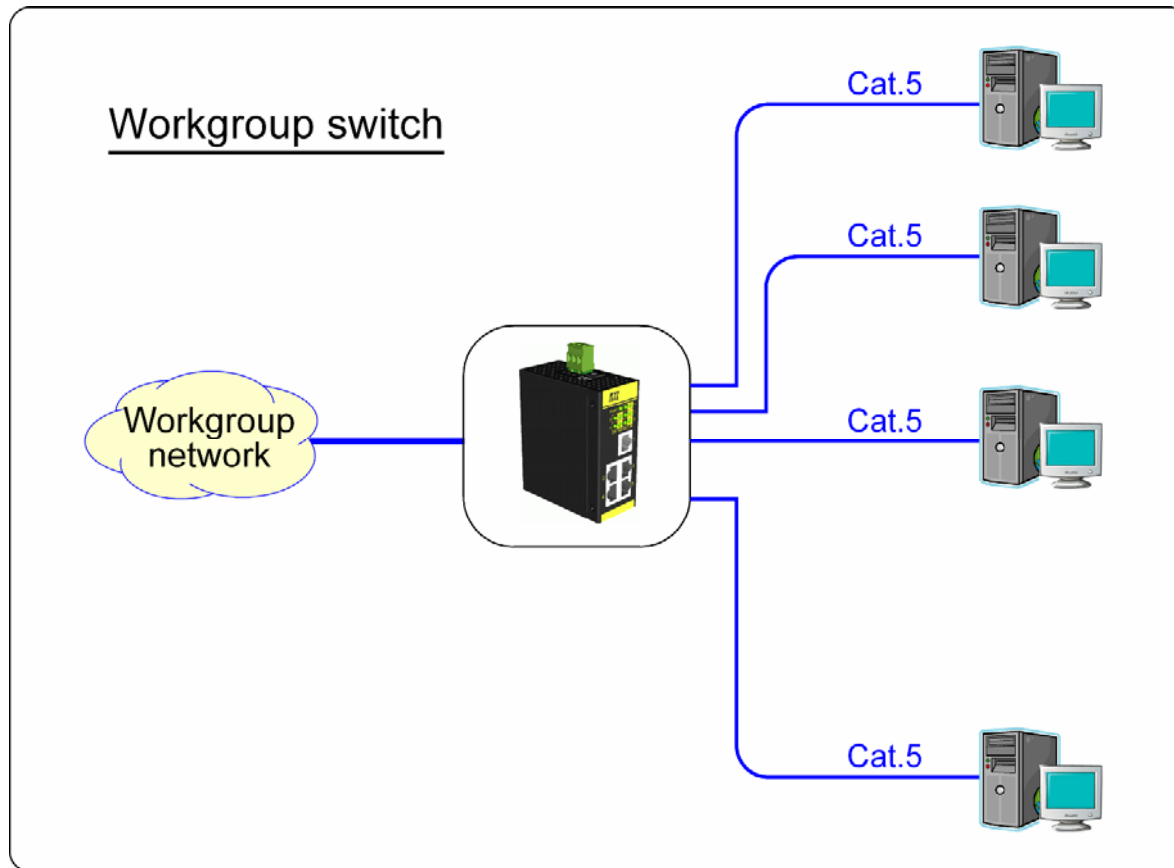

# Application Note : Recommended Power

## KTI's Power Supply Solutions for KFS-0540 and KFS-0840

### Power Supply Specification

Item Power	Type	AC Input	Output Interface	Rated Input Voltage	Rated Output Voltage	Rated Power	Working Temp. (100% power)
KPW-1212-H-U	Adapter	US Type Plug	DC-Jack	100-240V	12V	12W	100%@-10~60°C
KPW-1212-H-V	Adapter	EU Type Plug	DC-Jack	100-240V	12V	12W	100%@-10~60°C
KPW-2012-D-E	Din-Rail	Terminal Block or IEC 320	Terminal Block or DC Jack	100-240V	12V	21.6W	100%@-20~60°C